

USERS MUST ASSURE THEY ARE USING THE CORRECT REVISION.

REVISIONS

REV	ECO NO.	DESCRIPTION	BY	DATE	APP'D BY	DATE
2		.102 WAS .062	JWJ	8/29/2003	RRR	8/29/2003
3		REVISED NOTE 1	K. KOONS	1/19/2015		
4		REVISED PICTORIALY	K. KOONS	1/13/2017		

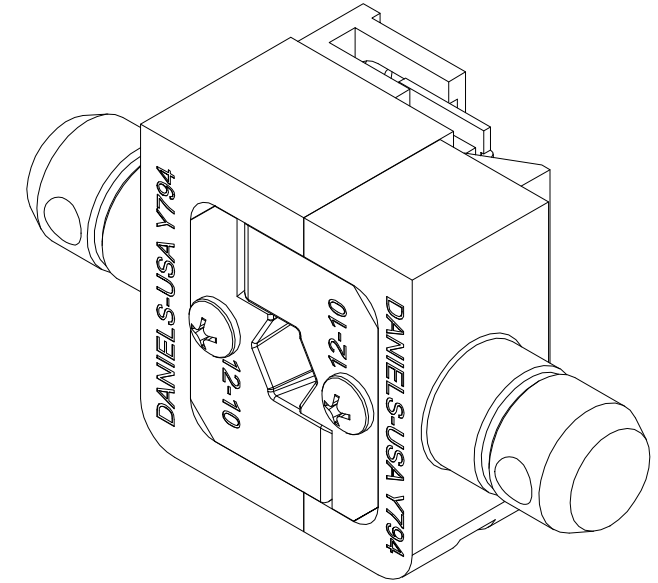
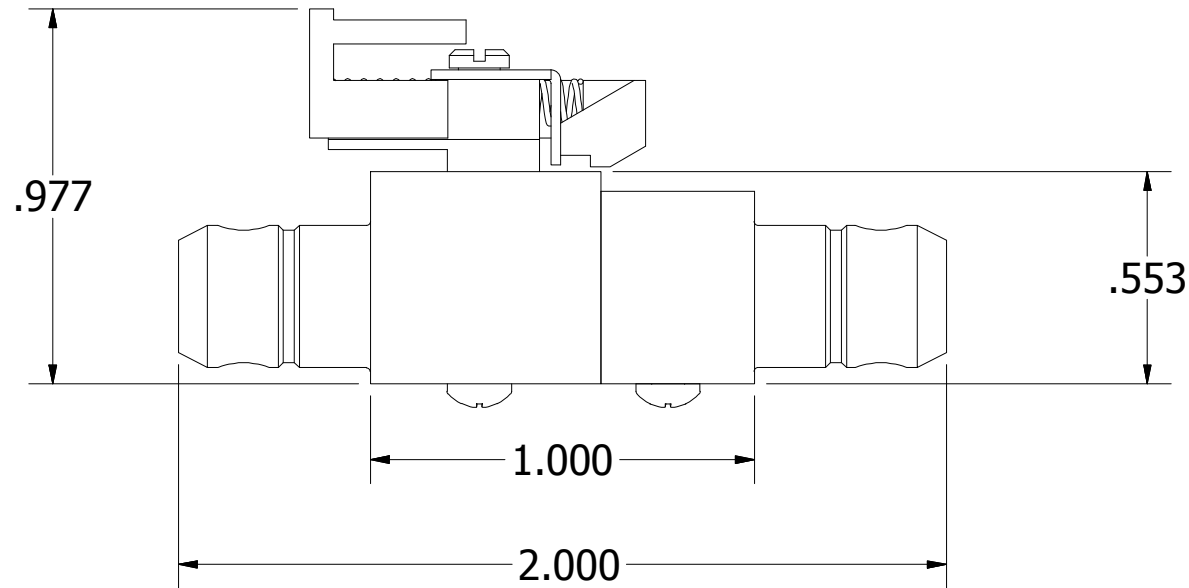

ISOMETRIC VIEW
REF ONLY

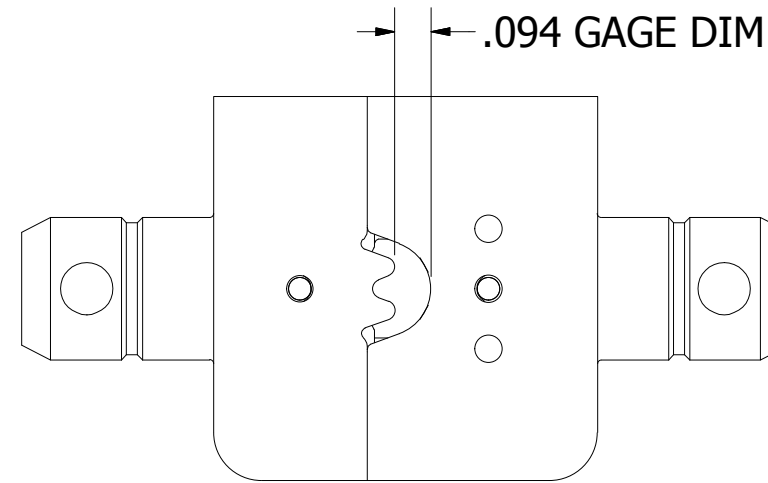
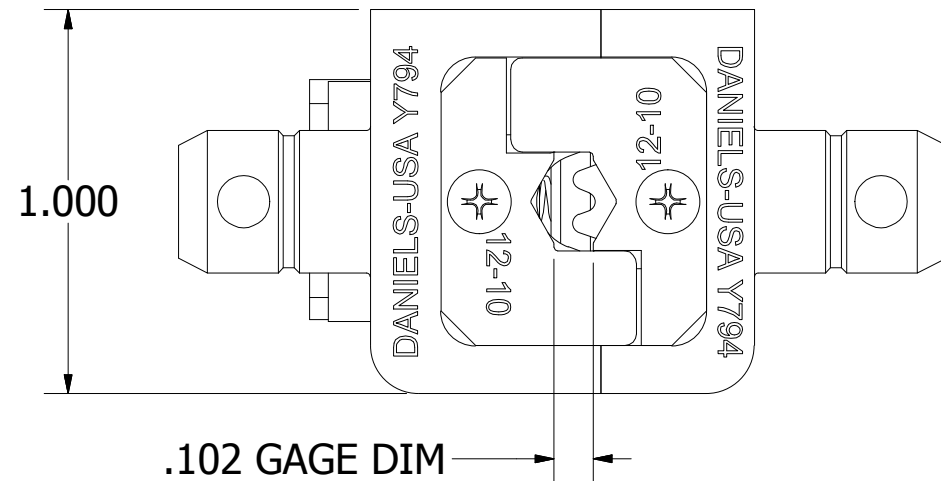

BACK VIEW

**UNCONTROLLED DOCUMENT
WILL NOT BE UPDATED**

DIMENSIONS IN INCHES - UNLESS OTHERWISE SPECIFIED

1. COMPARABLE CONFIGURATION TO TE (AMP)
59461 ON CENTER GAGING STEP ONLY.

NOTES:

MATERIAL	ITEM	PART NO.	QTY.	DESCRIPTION / REMARKS
NA	DRN. KCK CHK'D. ENF	DATE 8/8/2013 DATE 6/4/2014		DMC DANIELS MANUFACTURING CORP. ORLANDO, FLORIDA CAGE 11851
RESTRICTED & CONFIDENTIAL CONFIDENTIAL PROPERTY OF DANIELS MANUFACTURING CORP. NOT TO BE DISCLOSED TO OTHERS. REPRODUCTION OR USED FOR ANY OTHER PURPOSE EXCEPT AS AUTHORIZED IN WRITING BY DANIELS MANUFACTURING. MUST BE RETURNED TO DANIELS MANUFACTURING CORP. ON COMPLETION OF ORDER OR PURPOSES FOR WHICH LENT.	HEAT TREAT	NOTE: THIS DRAWING IS AN OUTLINE DRAWING OF THE RESPECTIVE DMC PART NUMBER INDICATED. ACTUAL DMC PART NUMBER IS CAD PART NUMBER WITHOUT THE "-ENV" SUFFIX	TITLE DIE SET, 12-10 AWG ENVELOPE DRAWING	
CREATED FROM AN INVENTOR MODEL. CHANGES MUST BE REFLECTED IN THE 3D PART	FINISH	NA	WHERE USED: SIZE B SCALE 2 : 1	CAD P/N Y794-ENV SHEET 1 OF 1 DWG. NO. Y794 REV. 4
DO NOT SCALE DRAWING				