

# WST8139

## WIRE SEPARATION TOOL

**DMC** DANIELS  
MANUFACTURING  
CORPORATION  
**DATASHEET**

SEE REVERSE SIDE FOR IMPORTANT INFORMATION CONCERNING LIMITED WARRANTY, AND LIMITATION OF LIABILITY.

### INTRODUCTION

The WST8139 Wire Separation Tool was developed for separating the blue and yellow wires of an S280W651-() Data Bus Cable apart when installing it in the E-Core of the ARINC 629 Coupler Base.

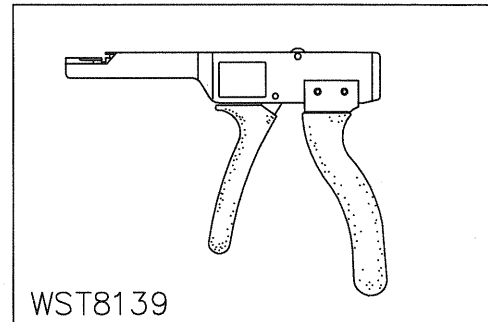

### CAUTION

DO NOT USE ANY TOOLS OTHER THAN THE WST8139 WIRE SEPARATOR TOOL FOR THIS REQUIREMENT. UNAPPROVED TOOLS CAN DAMAGE THE WIRE.

### PROCEDURE

(FOLLOWING ARE EXCERPTS FROM THE BOEING COMMERCIAL AIRPLANES STANDARD WIRING PRACTICES MANUAL D6-54446 WIRING CHAPTER 20).

1. Make an estimate of the location where you need to pull the blue and the yellow wires apart, so you can put them in the top and bottom grooves of the tool.
2. Put one wire in the lower jaw and the other wire in the upper jaw of the WST8139 tool as shown in Figure 1.
3. Pull the front trigger until it touches the back handle of the tool in order to pull the blue and yellow wires apart.
4. Remove the wires from the separator tool.

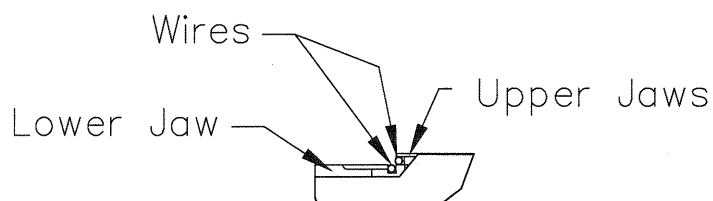

**FIGURE 1**

DMC offers complete refurbishing and recalibration services.

DMC specially engineers and manufactures complete tool kits to satisfy individual customer requirements, such as total aircraft support, general shop maintenance or production, on board ship and vehicle service, etc.

#### LIMITATION OF LIABILITY

DANIELS MANUFACTURING CORPORATION IS NOT LIABLE FOR CONSEQUENTIAL OR SPECIAL DAMAGES OF ANY NATURE OR KIND RESULTING FROM THE USE, OR MISUSE, OF ANY OF ITS PRODUCTS. OWNERS AND USERS OF DMC PRODUCTS ASSUME FULL RESPONSIBILITY FOR INSTRUCTING THEIR EMPLOYEES IN THE PROPER AND SAFE USE OF SUCH PRODUCTS.

#### LIMITED WARRANTY

DMC (Daniels Manufacturing Corporation) warrants each new product sold by it to be free from defects in material and workmanship under normal use and service. DMC's obligation under this warranty is limited to the free correction or, at DMC's option, the refund of the purchase price of any such product which proves defective in normal service within ninety (90) days after delivery to the first user, provided that the product is returned to DMC with all transportation charges prepaid and which shall appear to DMC's satisfaction, after DMC's inspection, to have been defective in material or workmanship, it being understood that DMC products are not consumer products. This warranty shall not cover any damage to any product which, in the opinion of DMC, was caused by normal wear, misuse, improper operation, tampering, neglect or accident. This warranty is in lieu of all other warranties express or implied. No warranty, express or implied, is made or authorized to be made or assumed with respect to products of Daniels Manufacturing Corporation other than those herein set forth.