

WSP-1626E PNEUMATIC WIRE STRIPPER

SEE PAGE 7 FOR IMPORTANT INFORMATION CONCERNING LIMITED WARRANTY, AND LIMITATION OF LIABILITY

The WSP-1626E Pneumatic Wire Stripper is for hand held stripping of most insulated wire from 16-26 AWG. The tool accommodates Ergo Elite Stripmaster® Laminated blades and pads made by Ideal Industries, Inc.

The wire stripper features a 360° rotatable head section that enables positioning of the head to most comfortable position for left, or right handed operators.

OPERATION

To operate the wire stripper, proceed as follows (See Figure 1):

1. Ensure that the proper blade set, and gripper pad sets are installed in the tool. If the blades or grippers need to be changed, refer to the procedure described later in this datasheet.
2. Loosen the thumb screw of the adjustable wire stop on the tool, and position it for the proper strip length to be stripped. Then re-tighten the thumb screw.
3. Hold the stripper in the hand which will be used for operation of the tool and position the activating lever where it feels most comfortable for operation. With the locking screw loosened, rotate the stripping head until it is positioned in a proper location for easy viewing and placement of the wire to be stripped. Tighten the locking screw). NOTE: It will be easier to rotate the head with the air supply disconnected, or with the tool in the activated position.
4. Connect the air hose to a clean, dry air supply between 80 - 120psi (5.5 - 8.3 bar).

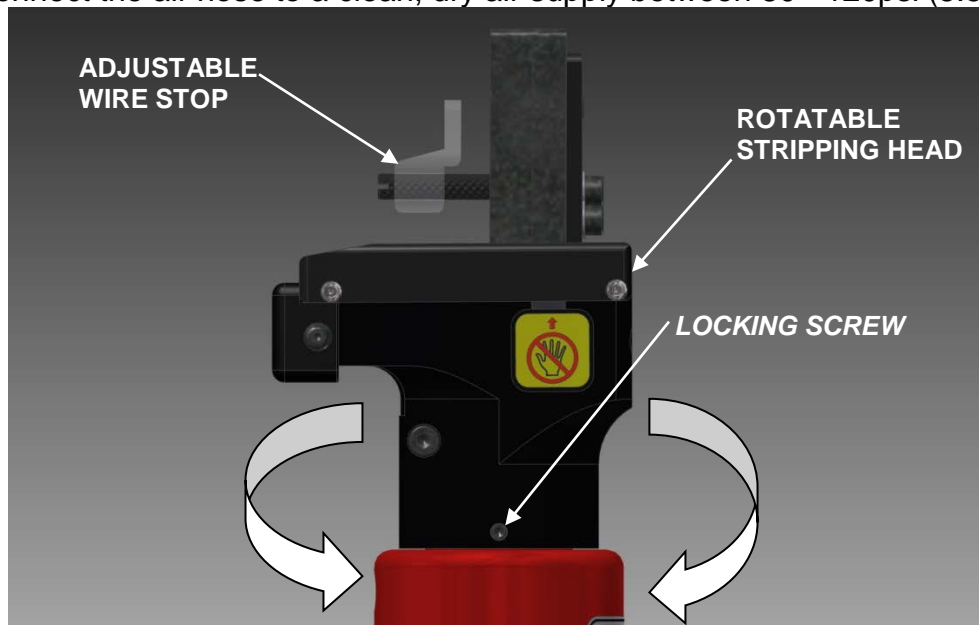

Figure 1

WSP-1626E PNEUMATIC WIRE STRIPPER

DATASHEET

5. Position the wire to be stripped into the proper cavity of the open blade set. The free end of the wire should be butted against the wire stop, and the rest of the length of wire should pass through in between the open gripper set.
6. While keeping the hand holding the wire as far away from the stripping head as possible, press the activating lever of the tool. The gripper, and blade sets will close, then the blade carrier will pull away from the gripper set.
7. Release the activating lever, and then remove the stripped wire.

GRIPPER AND BLADE SET REMOVAL AND INSTALLATION

Following is the procedure for changing the stripping blades and pads. Be sure the proper blades and pads are used for the type of wire being stripped.

Gripper Pads (See Figures 2 & 3):

1. Disconnect the tool from the air supply.
2. Remove the screw holding the gripper pads in place.
3. Remove the guide plate & stationary gripper.
4. Remove the movable gripper by rotating the gripper so the tang comes out of the activating link.
5. Install the new gripper set by reversing the above steps. **DO NOT OVERTIGHTEN** the holding screws.
6. Reconnect the air supply and activate the tool. If the movable gripper does not completely close to the stationary gripper, loosen the two screws, realign and close completely. Retighten with the two pads touching.

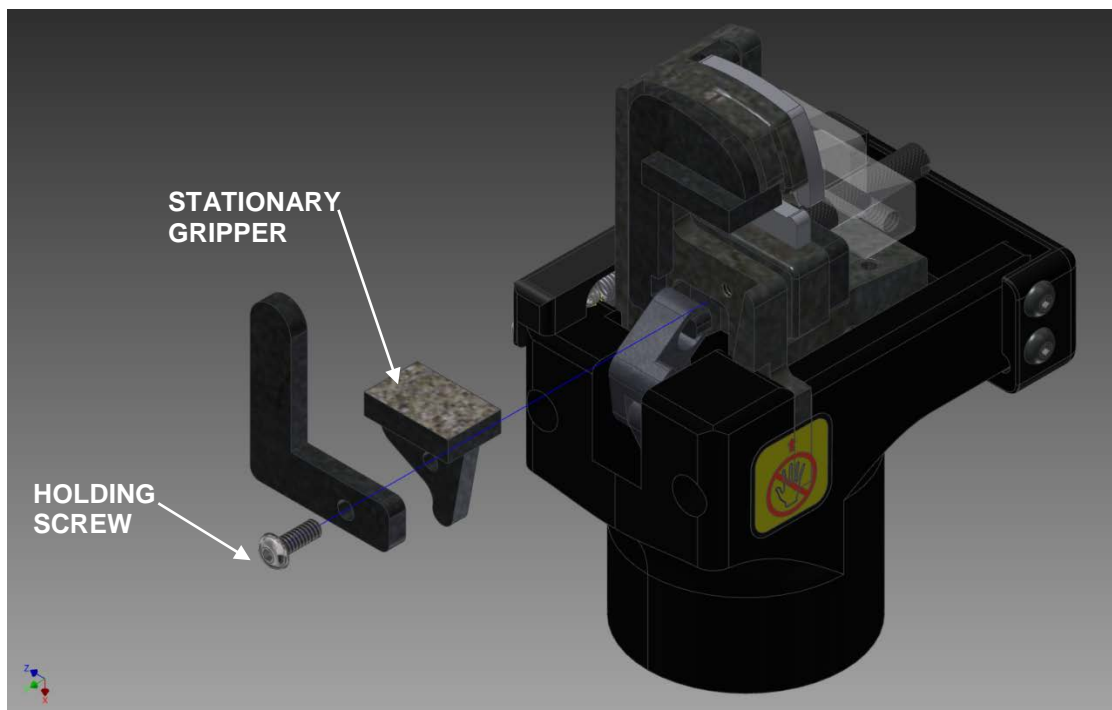

Figure 2

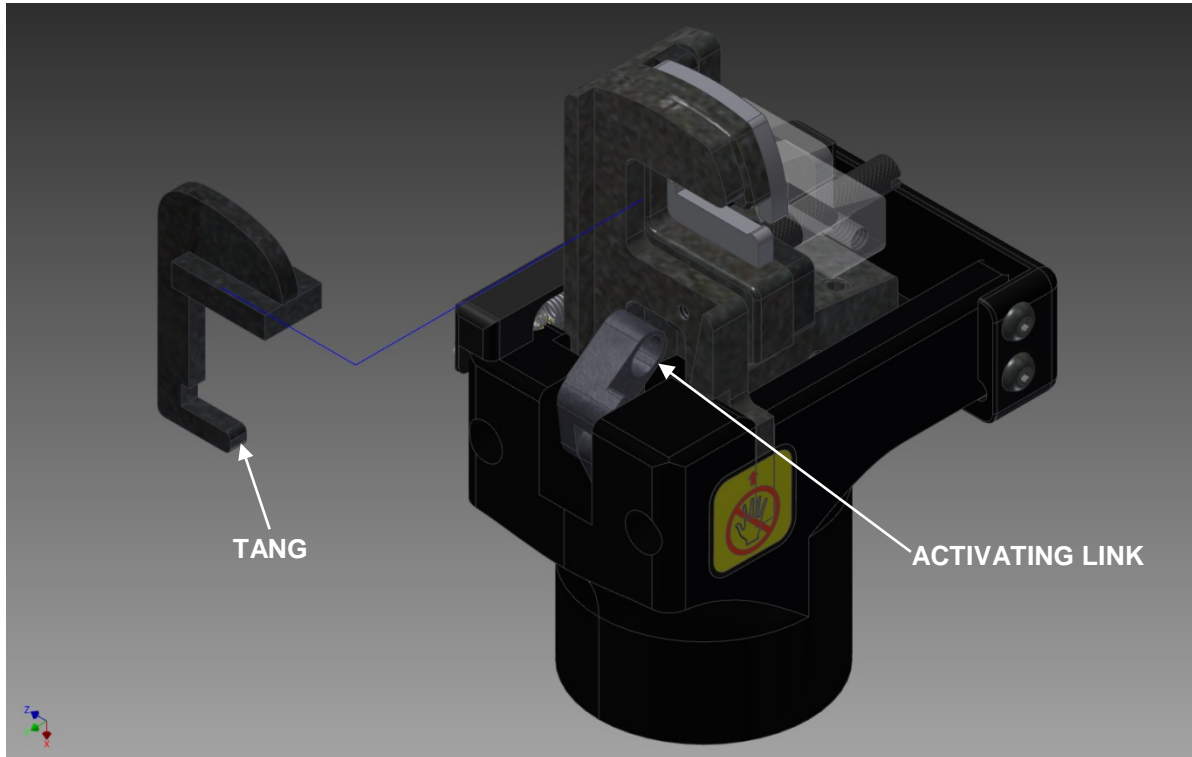

Figure 3

Blade Sets (See Figure 4):

1. Depress the activating lever, and with the carrier extended, disconnect the unit from the air supply.
2. Remove the wire stop and post holding the guide plate and stationary blade.
3. Remove the guide plate, and stationary blade.
4. Rotate the movable blade so the tang comes out of the activating link, then remove.
5. Reassemble the replacement blades by reversing the above steps.
6. Replace the screw, and wire stop post holding the guide plate and stationary blade. **DO NOT OVERTIGHTEN.**
7. Reconnect the air supply, and activate the tool. If the movable blade does not align properly, loosen the screw and wire stop post. Then realign to close completely. Then retighten the screw and post.

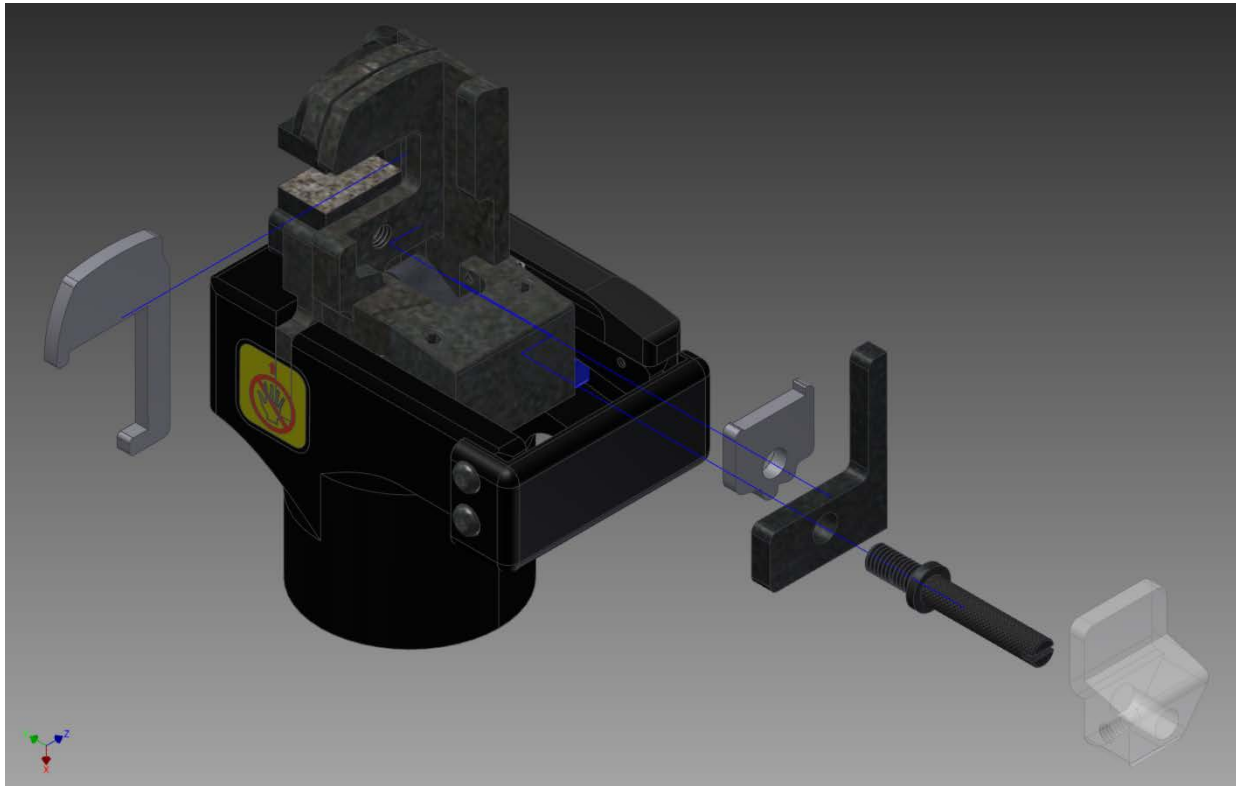

Figure 4

CARRIER BRAKE REPLACEMENT / ADJUSTMENT

(See Figure 5) The carrier contains two brakes which cause the gripper pads and stripping blades to close before the carrier advances, and strips the wire. They then delay the carrier from returning until the grippers and blades are open again. When this sequence does not occur properly, the carrier brakes may have worn sufficiently to require replacement, or adjustment. NOTE: These brakes have been properly adjusted at the factory. DO NOT adjust brakes, on a new tool.

To replace the brakes, remove the two adjustment set screws. Remove the springs, and the worn brakes. Re-install new brakes, and springs. Replace the adjustment set screws, tightening them until they are flush to the top of the carrier. Actuate the tool, and visually determine if the sequence is satisfactory. If further adjustment is needed, tighten the adjustment screws a $\frac{1}{4}$ of a turn, then activate the tool again. Repeat the process until the desired sequence is achieved.

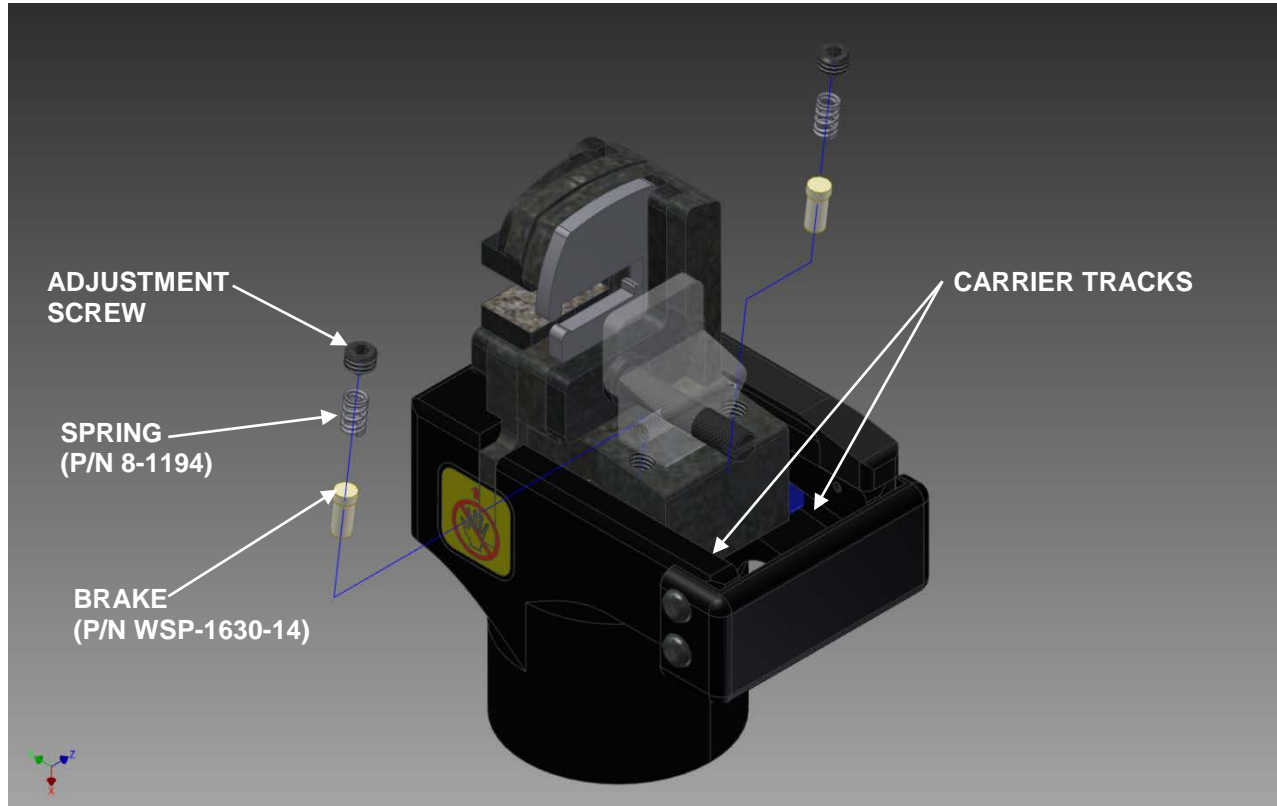

Figure 5

LUBRICATION

(See Figure 5) Periodic lubrication of the carrier in the carrier tracks will ensure smooth operation. Use a Teflon[®] or molybdenum based grease sparingly, once every 10,000 cycles.

AIR HOSE WITH FLOW CONTROL VALVE

An in-line flow control valve in the hose assembly allows the user to adjust the speed of the stripping action of the tool. The strip speed may be adjusted as follows (See Figure 6):

1. Connect the wire stripper to a clean, dry air supply with the pressure set between 80 - 120psi (5.5 – 8.3 bar).
2. Rotate the knurled body of the valve clockwise (looking at the bottom of the tool) until it is hand tight and fully closed.
3. Activating the tool will result in no operation, or extremely slow operation of the tool. Rotate the flow control valve body slowly counter clockwise, while activating the tool at the same time, until the preferred speed of operation is reached.
4. Full flow operation will be achieved in approximately one half turn.

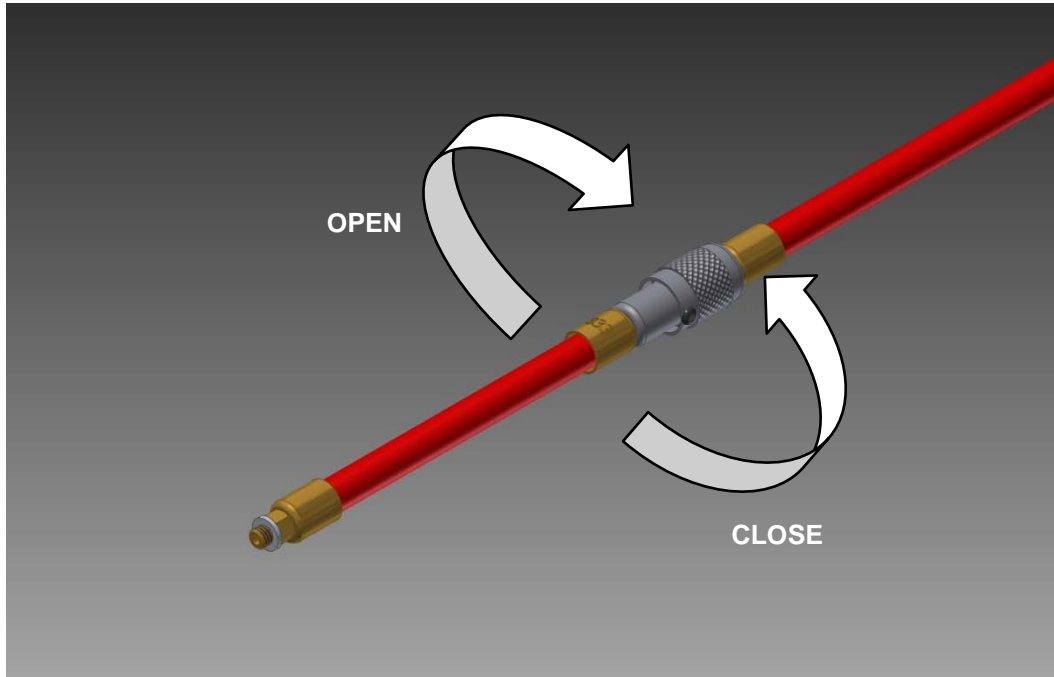

Figure 6

WSP-1626E

PNEUMATIC WIRE STRIPPER



DATASHEET

DMC offers complete refurbishing and recalibration services.

DMC specially engineers and manufactures complete tool kits to satisfy individual customer requirements, such as total aircraft support general shop maintenance or production, on board ship and vehicle service, etc.

Limitation of Liability

DANIELS MANUFACTURING CORPORATION IS NOT LIABLE FOR CONSEQUENTIAL OR SPECIAL DAMAGES OF ANY NATURE OR KIND RESULTING FROM THE USE, OR MISUSE, OF ANY OF ITS PRODUCTS. OWNERS AND USERS OF DMC PRODUCTS ASSUME FULL RESPONSIBILITY FOR INSTRUCTING THEIR EMPLOYEES IN THE PROPER AND SAFE USE OF SUCH PRODUCTS.

Limited Warranty

DMC (Daniels Manufacturing Corporation) warrants each new product sold by it to be free from defects in material and workmanship under normal use and service. DMC's obligation under this warranty is limited to the free correction or, at DMC's option, the refund of the purchase price of any such product which proves defective in normal service within ninety (90) days after delivery to the first user, provided that the product is returned to DMC with all transportation charges prepaid and which shall appear to DMC's satisfaction, after DMC's inspection, to have been defective in material and workmanship, it being understood that DMC products are not consumer products. This warranty shall not cover any damage to any product which, in the opinion of DMC, was caused by normal wear, misuse, improper operation, tampering, neglect or accident. This warranty is in lieu of all other warranties express or implied. No warranty, express or implied, is made or authorized to be made or assumed with respect to products of Daniels Manufacturing Corporation other than those herein set forth.