

USERS MUST ASSURE THEY ARE USING THE CORRECT REVISION.

REVISIONS						
REV	ECO NO.	DESCRIPTION	BY	DATE	APP'D BY	DATE
1		ORIGINAL RELEASE	K. KOONS	8/28/2014		

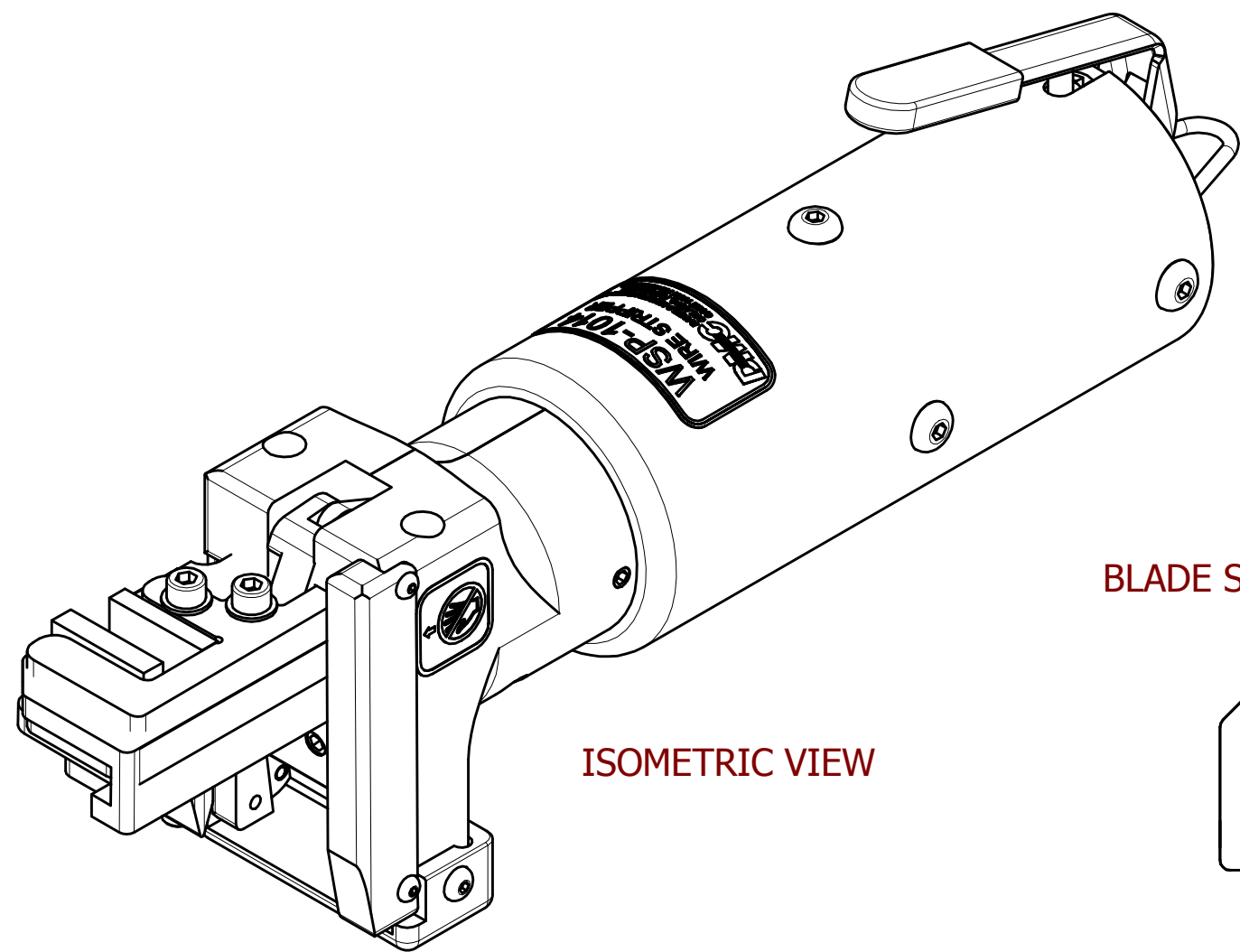

ISOMETRIC VIEW

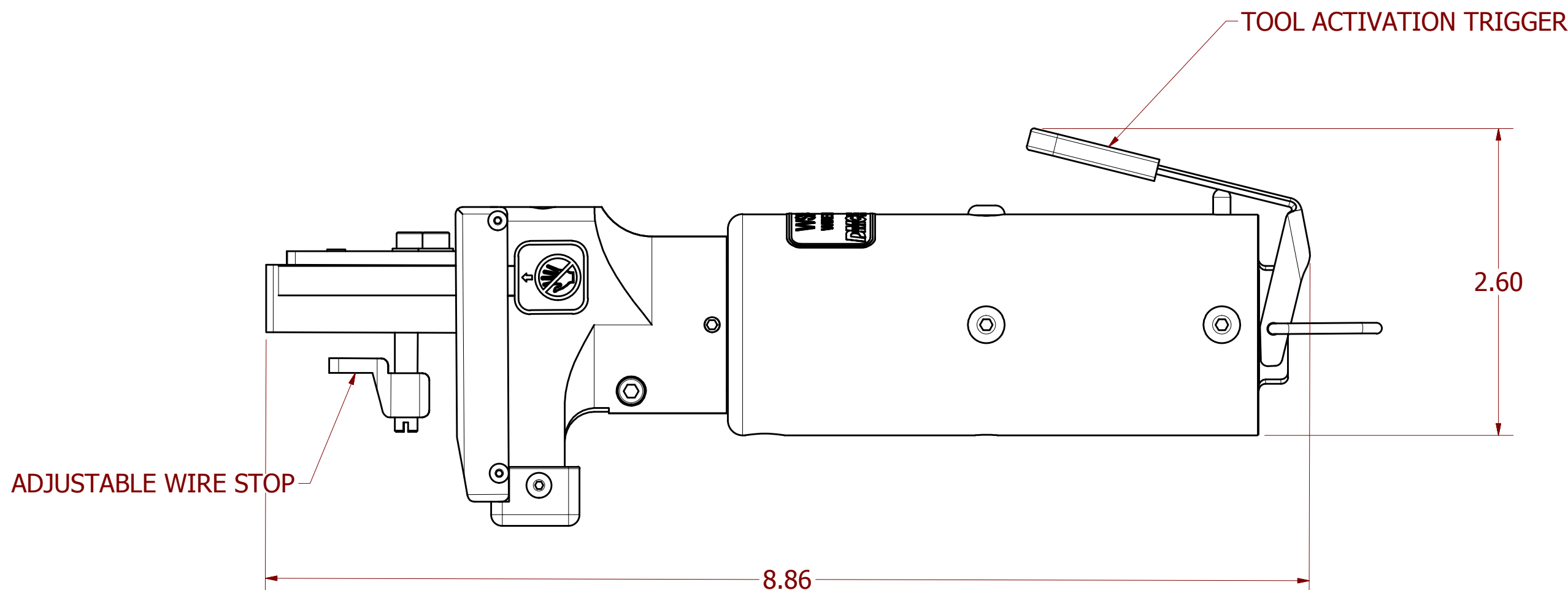
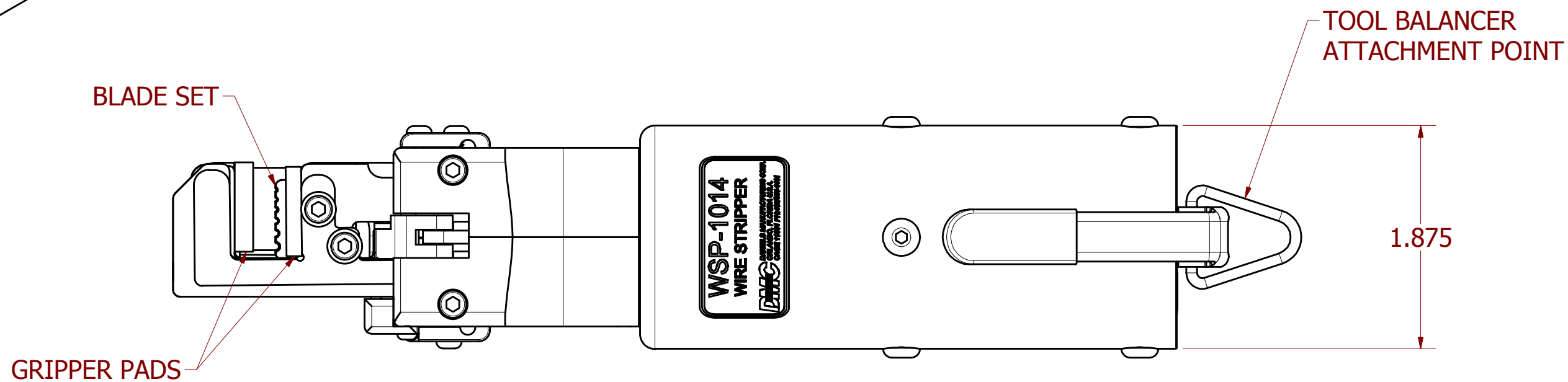

**UNCONTROLLED DOCUMENT
WILL NOT BE UPDATED**

DIMENSIONS IN INCHES - UNLESS OTHERWISE SPECIFIED

- 2. WIRE RANGE: 10 - 14 AWG.
- 1. WEIGHT: 2.32lb

NOTES:

RESTRICTED & CONFIDENTIAL
 CONFIDENTIAL PROPERTY OF DANIELS MANUFACTURING CORP. NOT TO BE DISCLOSED TO OTHERS. REPRODUCTION OR USED FOR ANY OTHER PURPOSE EXCEPT AS AUTHORIZED IN WRITING BY DANIELS MANUFACTURING. MUST BE RETURNED TO DANIELS MANUFACTURING CORP. ON COMPLETION OF ORDER OR PURPOSES FOR WHICH LENT.
 CREATED FROM AN INVENTOR MODEL.
 CHANGES MUST BE REFLECTED IN THE 3D PART
 DO NOT SCALE DRAWING

MATERIAL	ITEM	PART NO.	QTY.	DESCRIPTION / REMARKS
NA	DRN. KIRK C KOONS CHK'D. ENF	DATE 7/29/2013 DATE 7/10/2014		DMC DANIELS MANUFACTURING CORP. ORLANDO, FLORIDA CAGE 11851
HEAT TREAT NA	NOTE: THIS DRAWING IS AN OUTLINE DRAWING OF THE RESPECTIVE DMC PART NUMBER INDICATED. ACTUAL DMC PART NUMBER IS DRAWING NUMBER WITHOUT THE "-ENV" SUFFIX		TITLE PNEUMATIC WIRE STRIPPER, 10-14 AWG ENVELOPE DRAWING	
FINISH NA	WHERE USED:	SIZE C	SCALE 1 : 1	CAD P/N WSP-1014-ENV DWG. NO. WSP-1014-ENV
			SHEET 1 OF 1	REV. 1