

REVISIONS				
REV. SYM.	E.C.D. NUMBER	DESCRIPTION	BY DATE DATE	APP'D DATE DATE
1		ORIGINAL RELEASE	D.A.D. 3-18-98	DE 3-98

**UNCONTROLLED DOCUMENT  
WILL NOT BE UPDATED**

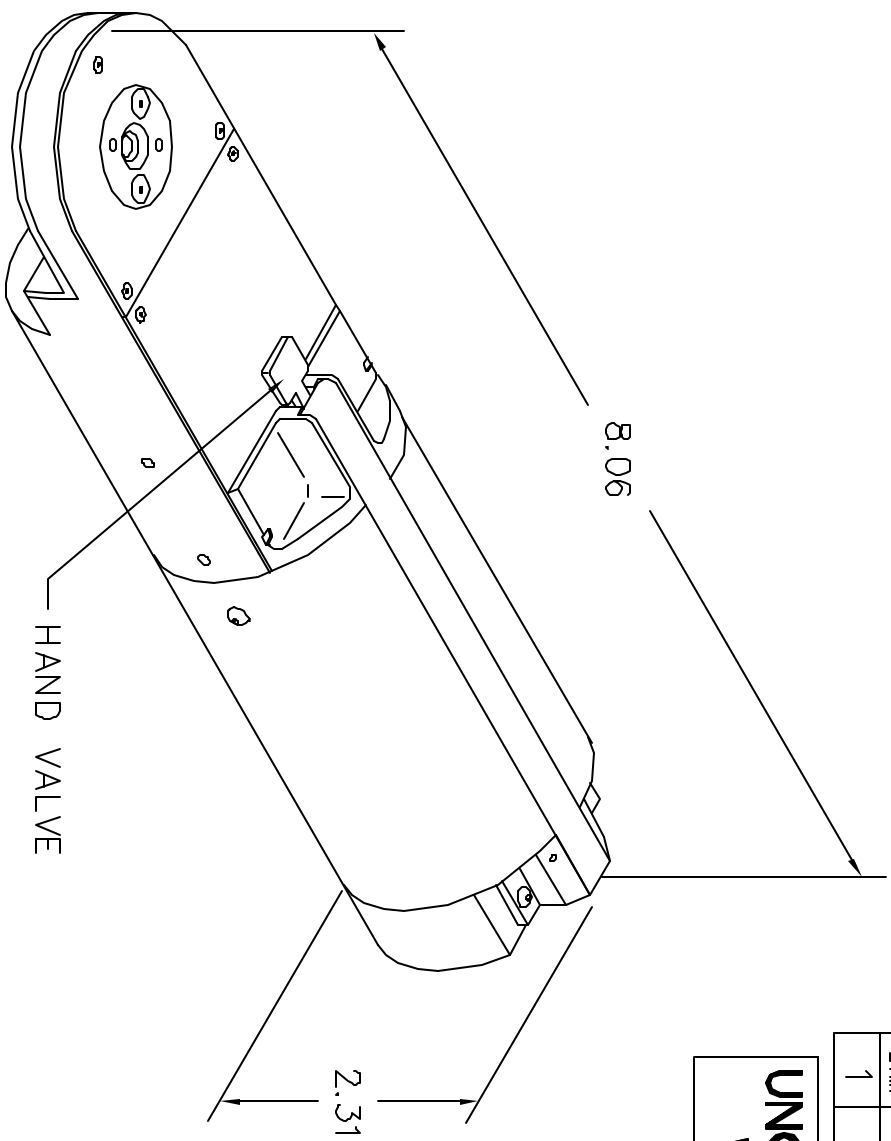

DIE CLOSURES		
SEL NO	Ø GD	Ø NO-GO
1	.0140	.0160
2	.0170	.0190
3	.0200	.0220
4	.0230	.0250
5	.0270	.0290
6	.0310	.0330
7	.0350	.0370
8	.0400	.0420

USE GAGE G100 AT  
SELECTOR SETTING 3

**RESTRICTED & CONFIDENTIAL**  
 CONFIDENTIAL PROPERTY OF DANIELS  
 MANUFACTURING CORP. NOT TO BE  
 DISCLOSED TO OTHERS, REPRODUCED  
 OR USED FOR ANY OTHER PURPOSE,  
 EXCEPT AS AUTHORIZED IN WRITING  
 BY DANIELS MANUFACTURING.  
 MUST BE RETURNED TO DANIELS  
 MANUFACTURING CORP. ON COMPLETION  
 OF ORDER OR OTHER PURPOSE FOR  
 WHICH LENT.

DO NOT SCALE DRAWING

DRN.	D.DEPAVA	DATE	3-18-98
CHKD.	DE	DATE	3-98
APP'D.		DATE	
APP'D.		DATE	

NOTE:  
 THIS DRAWING IS AN OUTLINE  
 DRAWING OF THE RESPECTIVE  
 DMG PART NUMBER  
 INDICATED. ACTUAL DMG  
 PART NUMBER IS DRAWING  
 NUMBER WITHOUT  
 THE "-ENV" SUFFIX

TITLE			
<b>PNEUMATIC CRIMP TOOL ENVELOPE DRAWING</b>			
WHERE USED:			
SIZE	SCALE	CAD P/N	SHEET OF
A	NTS	WA22H-ENV	1 OF 1
POSTING		DWG. NO.	REV.
		WA22H-ENV	1



DANIELS MANUFACTURING CORP.  
 ORLANDO, FLORIDA  
 CAGE 11851