

REVISIONS				
REV. SYM.	E.C.O. NUMBER	DESCRIPTION	BY DATE	APP'D DATE
1		ORIGINAL RELEASE	AAM 3-27-97	DE 3-97

**UNCONTROLLED DOCUMENT
WILL NOT BE UPDATED**

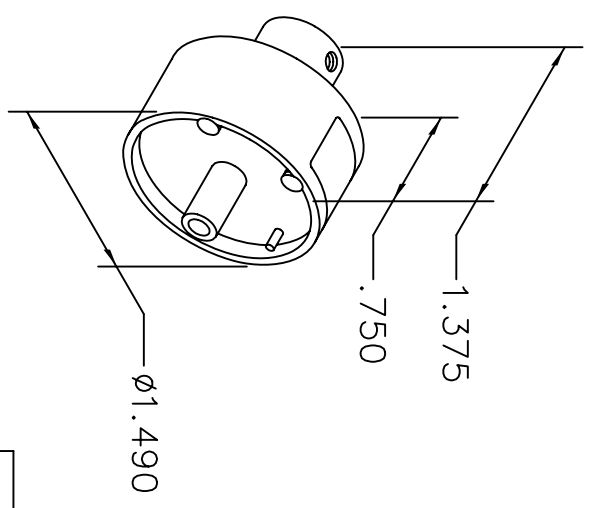

HOLE DIMENSIONS	ADDITIONAL FEATURES
ø.067	└┘ ø.191
▽.624	▽.42

HYPERTAC	20	18	16	WIRE SIZE
HPW-208-7	4	5	6	SELECTOR NUMBER

DATAPLATE

RESTRICTED & CONFIDENTIAL																					
<p>CONFIDENTIAL PROPERTY OF DANIELS MANUFACTURING CORP. NOT TO BE DISCLOSED TO OTHERS, REPRODUCED OR USED FOR ANY OTHER PURPOSE, EXCEPT AS AUTHORIZED IN WRITING BY DANIELS MANUFACTURING. MUST BE RETURNED TO DANIELS MANUFACTURING CORP. ON COMPLETION OF ORDER OR OTHER PURPOSE FOR WHICH LENT.</p>																					
<p>DO NOT SCALE DRAWING</p>	<p>NOTE: THIS DRAWING IS AN OUTLINE DRAWING OF THE RESPECTIVE DMG PART NUMBER INDICATED. ACTUAL DMG PART NUMBER IS DRAWING NUMBER WITHOUT THE "-ENV" SUFFIX.</p>																				
<table border="1" style="width: 100%;"> <tr> <th>ITEM</th> <th>PART NO.</th> <th>QTY.</th> <th>DESCRIPTION/REMARKS</th> </tr> <tr> <td>DRN. A. MOO-YOUNG</td> <td>DATE 3-27-97</td> <td></td> <td></td> </tr> <tr> <td>CHK'D.</td> <td>DATE</td> <td></td> <td></td> </tr> <tr> <td>APP'D.</td> <td>DATE</td> <td></td> <td></td> </tr> <tr> <td>APP'D.</td> <td>DATE</td> <td></td> <td></td> </tr> </table>	ITEM	PART NO.	QTY.	DESCRIPTION/REMARKS	DRN. A. MOO-YOUNG	DATE 3-27-97			CHK'D.	DATE			APP'D.	DATE			APP'D.	DATE			<p>WHERE USED:</p> <p>SIZE A SCALE NTS POSTING</p> <p>CAD P/N TP1177-ENV DWG. NO. TP1177-ENV</p> <p>SHEET 1 OF 1 REV. 1</p>
ITEM	PART NO.	QTY.	DESCRIPTION/REMARKS																		
DRN. A. MOO-YOUNG	DATE 3-27-97																				
CHK'D.	DATE																				
APP'D.	DATE																				
APP'D.	DATE																				

DMC
DANIELS MANUFACTURING CORP.
ORLANDO, FLORIDA
CAGE 11851

ENVELOPE DRAWING
SINGLE POSITION HEAD