

WINCHESTER CONTACTS	COLOR CODE	28	26	24	22	20	18	16	14	12	WIRE SIZE
100-0813P	RED								5	6	
100-811P-4188	RED								5	6	
100-2020PK				4	5						
100-1016PK						5	6	6			
100-1020PK	BLUE			4	4	5					
100-1022PK				4	5	5					
100-1024PK				4	5	5					
100-1014PK							5	5	6		
100-5018 P&S	YELLOW					5	6	7			

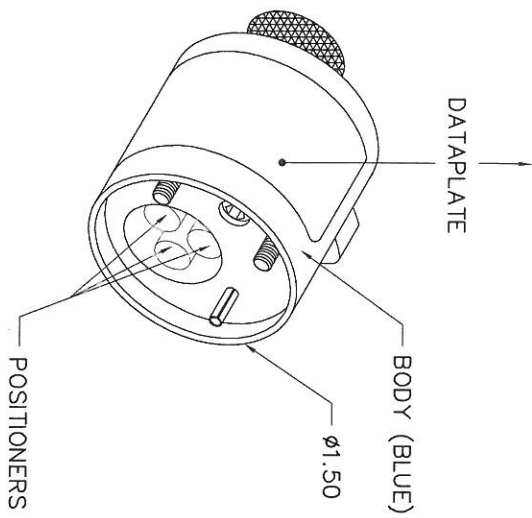

POSITIONER COLOR	HOLE DIMENSIONS	ADDITIONAL FEATURES
BLUE	$\phi .067$ $\pm .432$	$\perp \phi .128$ $\pm .340$
YELLOW	$\phi .136$ $\pm .847$	$\perp \phi .152$ $\pm .130$
RED	$\phi .067$ $\pm .478$	$\perp \phi .125$ $\pm .190$

NOTE: ALL DIMENSIONS ARE TAKEN FROM THE TOP OF THE POSITIONER INSERTS.

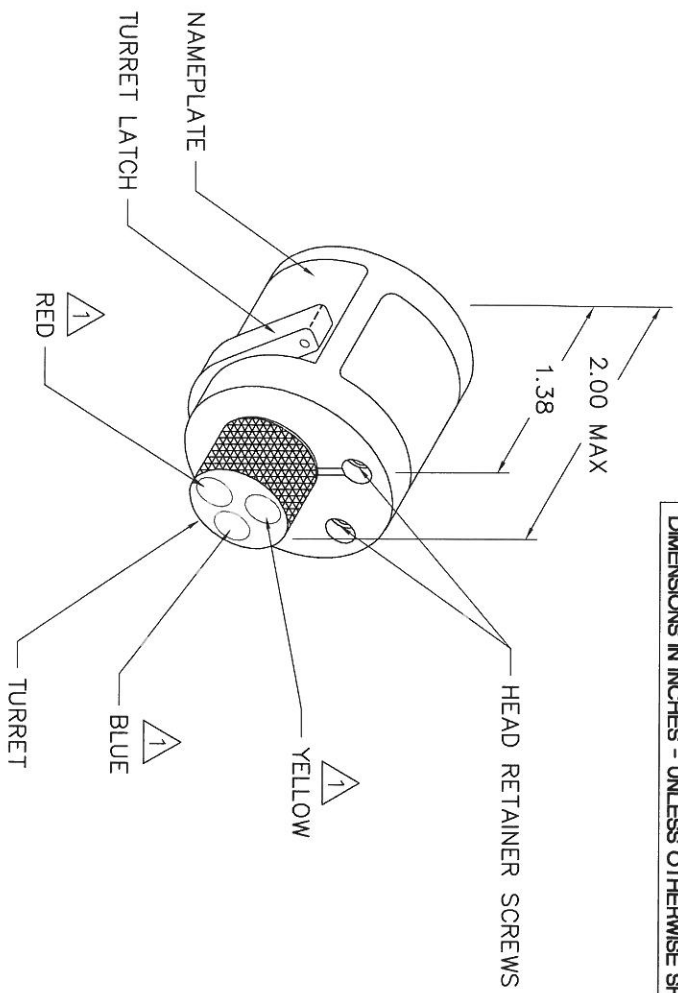

1 RANDOM ORDER OF ROTATION IS ACCEPTABLE.

**UNCONTROLLED DOCUMENT  
WILL NOT BE UPDATED**  
DIMENSIONS IN INCHES - UNLESS OTHERWISE SPECIFIED

REV. SYL.	E.C.O. NUMBER	DESCRIPTION	BY DATE	APP'D DATE
1		ORIGINAL RELEASE	7-2-98	

RESTRICTED & CONFIDENTIAL  
CONFIDENTIAL PROPERTY OF DANIELS MANUFACTURING CORP. NOT TO BE REPRODUCED OR USED FOR ANY OTHER PURPOSES EXCEPT AS AUTHORIZED IN WRITING BY DANIELS MANUFACTURING. MUST BE RETURNED TO DANIELS MANUFACTURING CORP. ON COMPLETION OF ORDER OR OTHER PURPOSE FOR WHICH LEN.

ITEM	PART NO.	QTY.	DESCRIPTION/REMARKS
DRN. A. MOO-YOUNG	DATE 7-2-98		
CHK'D	DATE		
APP'D.	DATE		
APP'D.	DATE		

NOTE: THIS DRAWING IS AN OUTLINE DRAWING. ALL DIMENSIONS INDICATED. ACTUAL DMC PART NUMBER IS CAD PART NUMBER WITHOUT THE "-ENV" SUFFIX.

WHERE USED:	SCALE	CAD P/N	SHEET OF
POSTING	B	TH491-ENV	1
	NTS		1

TITLE: ENVELOPE DRAWING  
TURRET HEAD

DANIELS MANUFACTURING CORP.  
ORLANDO, FLORIDA  
CAGE 11851

P/N TH491