

| REVISIONS  |               |                  |               |
|------------|---------------|------------------|---------------|
| REV. STYL. | E.C.O. NUMBER | DESCRIPTION      | BY DATE       |
| 1          |               | ORIGINAL RELEASE | JMM<br>6/5/03 |
|            |               |                  | APP'D<br>DATE |

**UNCONTROLLED DOCUMENT  
WILL NOT BE UPDATED**

| CONTACTS     | COLOR CODE | 16           | 18 | 20 | 22 | 24 | 26 | WIRE SIZE |
|--------------|------------|--------------|----|----|----|----|----|-----------|
|              |            | SELECTOR NO. |    |    |    |    |    |           |
| BURNDY       |            |              |    |    |    |    |    |           |
| YHMM20-2-DB8 | RED        |              |    | 7  | 6  | 5  |    |           |
| YHMM22-2-DB8 |            |              |    |    |    |    |    |           |
| YHMM16-5-DB8 | BLUE       | 7            | 7  | 6  | 6  |    |    |           |

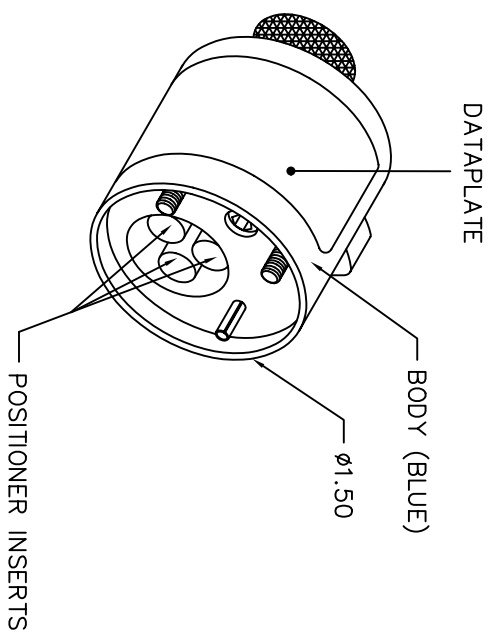

| POSITIONER COLOR | HOLE DIMENSIONS           | ADDITIONAL FEATURES                 |
|------------------|---------------------------|-------------------------------------|
| RED              | $\phi$ .098<br>$\pm$ .355 | $\square$ $\phi$ .113<br>$\pm$ .030 |
| BLUE             | $\phi$ .098<br>$\pm$ .365 | $\square$ $\phi$ .113<br>$\pm$ .050 |

HOLE AND COUNTERBORE DEPTHS ARE MEASURED FROM TOP OF POSITIONER INSERTS.

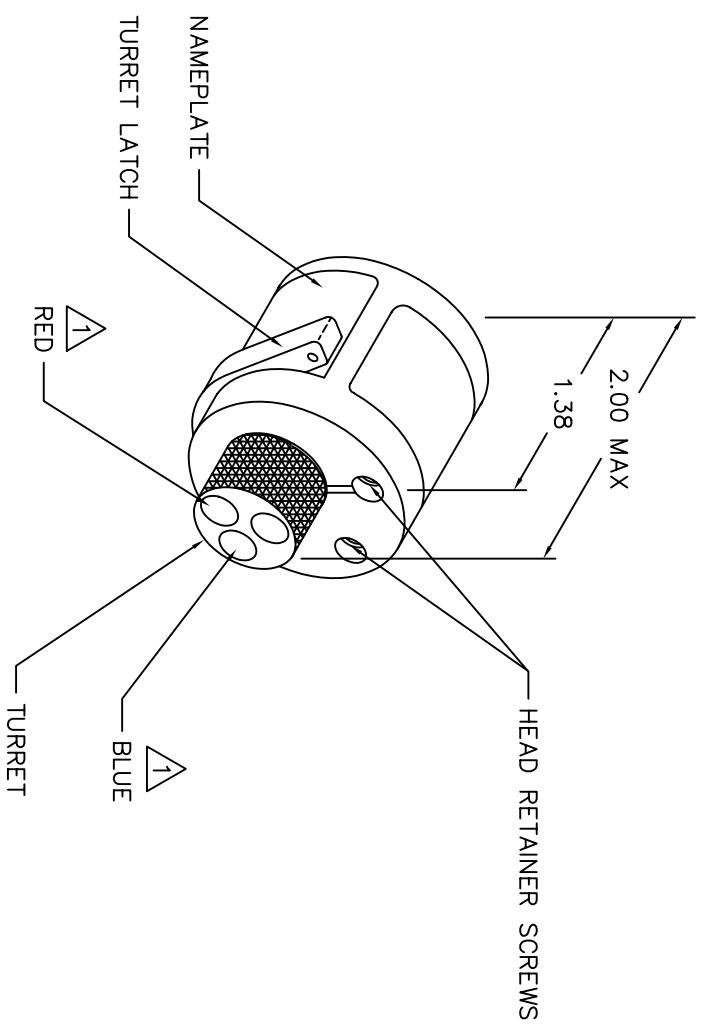

$\triangle 1$  RANDOM ORDER OF ROTATION IS ACCEPTABLE.

|   |             |  |                     |
|---|-------------|--|---------------------|
| <b>RESTRICTED &amp; CONFIDENTIAL</b>  |             | CONFIDENTIAL PROPERTY OF DANIELS MANUFACTURING CORP. NOT TO BE DISCLOSED OR REPRODUCED OR USED FOR ANY OTHER PURPOSE EXCEPT AS AUTHORIZED IN WRITING BY DANIELS MANUFACTURING. MUST BE RETURNED TO DANIELS MANUFACTURING CORP. ON COMPLETION OF ORDER OR OTHER PURPOSE FOR WHICH LENT. |                     |
| ITEM  | PART NO.    | QTY.   | DESCRIPTION/REMARKS |
| DRW. 1. JOYCE   | DATE 6/5/03 |  |                     |
| CHK'D. RRR  | DATE 6/5/03 |  |                     |
| APP'D.  | DATE        |  |                     |
| APP'D.  | DATE        |  |                     |
| NOTE: THIS DRAWING IS AN OUTLINE DRAWING OF THE RESPECTIVE DIM. PART NUMBER IS DRAWING PART NUMBER WITHOUT THE "-ENV" SUFFIX. |             |  |                     |
| DO NOT SCALE DRAWING  |             | WHERE USED: AFB  |                     |
| TITLE: ENVELOPE DRAWING   |             | CAD P/N: TH441-ENV   | SHEET 1 OF 1        |
| TURRET HEAD   |             | DWG. NO. TH441-ENV   | REV. 1              |
| DANIELS MANUFACTURING CORP. ORLANDO, FLORIDA CASE 11851   |             |  |                     |