

| DEUTSCH CONTACTS | COLOR CODE | 26 | 24 | 22 | 20 | WIRE SIZE SELECTOR NO. |
|----------------------------|------------|----|----|----|----|------------------------|
| 800-20/32-1 800-20/30-1 | RED | 2 | 2 | 3 | 4 | |
| 0641-10-2056 | BLUE | 1 | 2 | 3 | 4 | |
| 1841-1-5620 | GREEN | 1 | 2 | 3 | 4 | |

| POSITIONER COLOR | * HOLE DIMENSIONS | ADDITIONAL FEATURES |
|------------------|--------------------------------------|--|
| RED | $\varnothing .098$ $\pm .845$ MIN | $\perp \varnothing .125$ $\pm .140$ |
| BLUE | $\varnothing .085$ $\pm .845$ MIN | |
| GREEN | $\varnothing .085$ $\pm .845$ MIN | |

* HOLE DEPTH DIMENSIONS ARE MEASURED FROM THE TOP OF THE POSITIONER INSERTS.

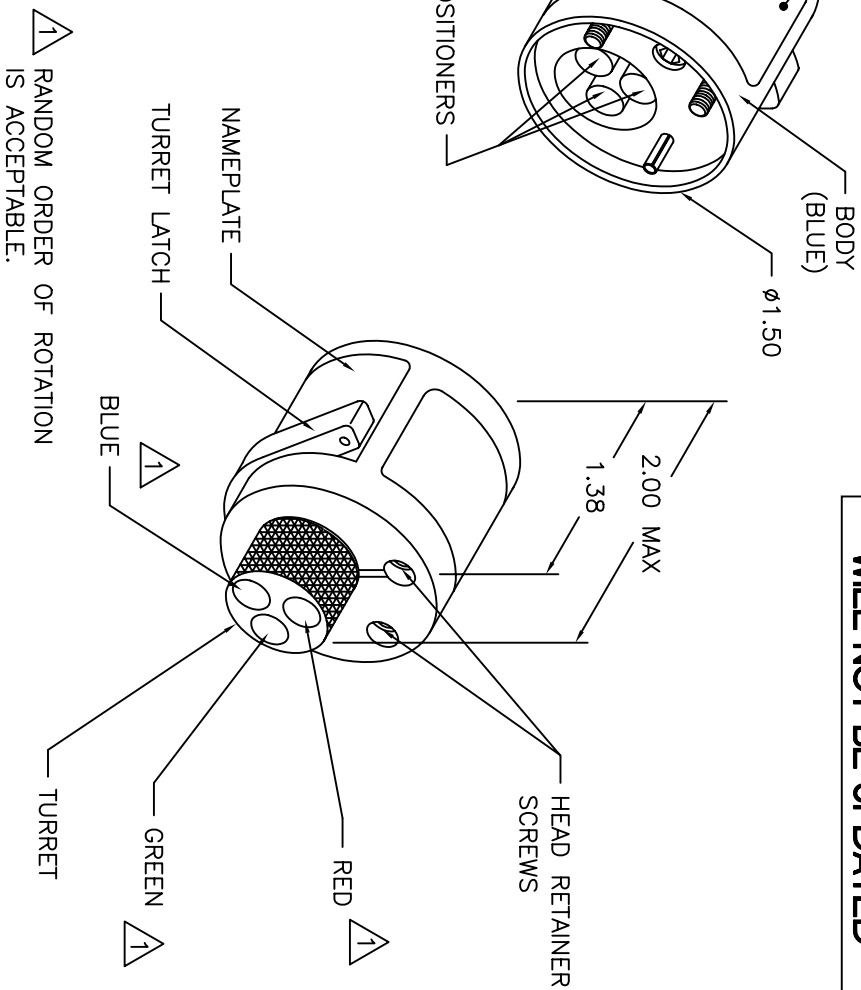
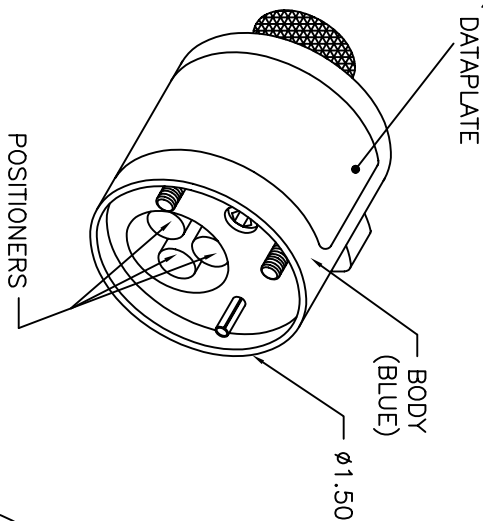

| REV | E.C.O NUMBER | DESCRIPTION | BY DATE | APP'D DATE |
|-----|--------------|------------------|------------|------------|
| 1 | | ORIGINAL RELEASE | JMC 8-9-03 | JMU 8-9-03 |

**UNCONTROLLED DOCUMENT
WILL NOT BE UPDATED**

| RESTRICTED & CONFIDENTIAL | ITEM | PART NO. | QTY. | DESCRIPTION/REMARKS |
|---|--------|----------|--------|---|
| CONFIDENTIAL PROPERTY OF DANIELS MANUFACTURING CORP. NOT TO BE DISCLOSED TO OTHERS, REPRODUCED OR USED FOR ANY OTHER PURPOSE, EXCEPT AS AUTHORIZED IN WRITING BY DANIELS MANUFACTURING. MUST BE RETURNED TO DANIELS MANUFACTURING CORP. ON COMPLETION OF ORDER OR OTHER PURPOSE FOR WHICH LENT. | DRN. | JMC | 8-5-03 | DANIELS MANUFACTURING CORP. ORLANDO, FLORIDA CASE 11851 |
| | CHK'D. | JWJ | 8-5-03 | |
| | APP'D. | | | |
| | DATE | | | |

| DO NOT SCALE DRAWING | THIS DRAWING IS AN OUTLINE DRAWING OF PART. RESPECTIVE DIMENSIONS INDICATED. ACTUAL DIM PART NUMBER IS DRAWING NUMBER WITHOUT THE "-ENV" SUFFIX. | NOTE: | WHERE USED: | CAD P/N | SHEET OF |
|----------------------|--|-------|-------------|-----------|----------|
| | | | AFB | TH260-ENV | 1 |
| | | | | TH260-ENV | 1 |
| | | | | TH260-ENV | 1 |