

MINIATURE SPECIAL PURPOSE HAND CRIMP TOOL

DMC DANIELS
MANUFACTURING
CORPORATION
DATASHEET

THIS HAND TOOL MUST NOT BE USED IN ANY POWERED "PRESS" AS DEFINED BY OSHA CFR 1910.211 (46)

SEE REVERSE SIDE FOR IMPORTANT INFORMATION CONCERNING LIMITED WARRANTY, AND LIMITATION OF LIABILITY.

GENERAL INFORMATION

- * Model number of the tool refers to both the positioner and tool frame as a combined unit.
- * The tool has a double action ratchet. Note that the tool cannot be opened without completing the crimp cycle.

SPECIFICATIONS

Tool No. 2745-1	Wire
Gage Go .025 No Go .030	* 20,22
Contacts: M39029/4-110 M39029/5-115 * 27% NICKEL	

CRIMPING INSTRUCTIONS

1. With tool in the open position, insert the contact and prepared wire through the opening and into the positioner.
2. Squeeze the handles together until the ratchet releases. Handles will return to the open position. Remove the crimped contact and wire.

TOOL NO. 2745-1

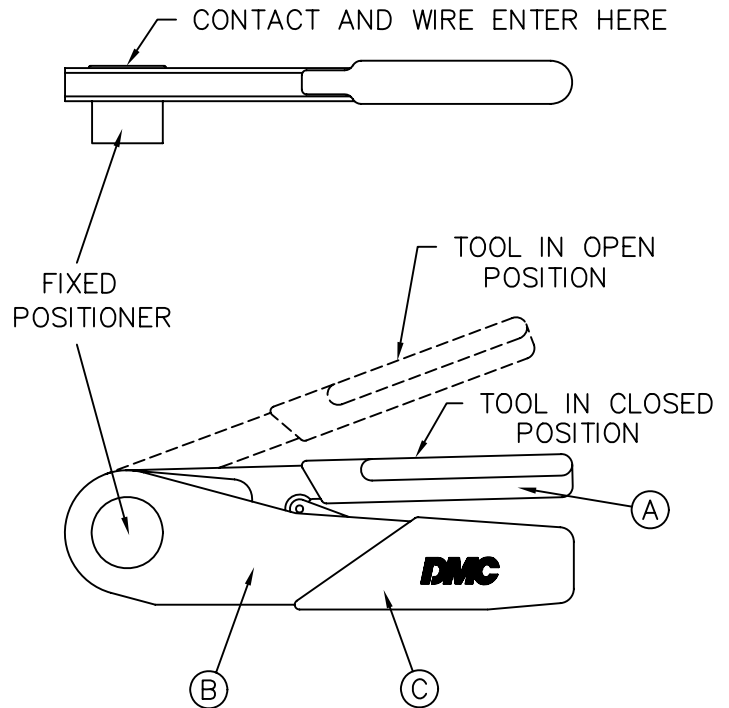

COLOR CODE

(A) BLUE (B) RED (C) BLUE

GAGING INSTRUCTIONS

"GO" GAGING

Operate the tool to the fully closed position. Maintain firm hand pressure on the tool handles. Insert the "GO" gage end as shown. The gage must pass freely between the indenter tips.

"NO-GO" GAGING

Operate the tool to the fully closed position. Maintain firm hand pressure on the tool handles. Try to insert the "NO-GO" gage end as shown. The "NO-GO" gage may enter the indenter opening, but must not pass completely through the opening.

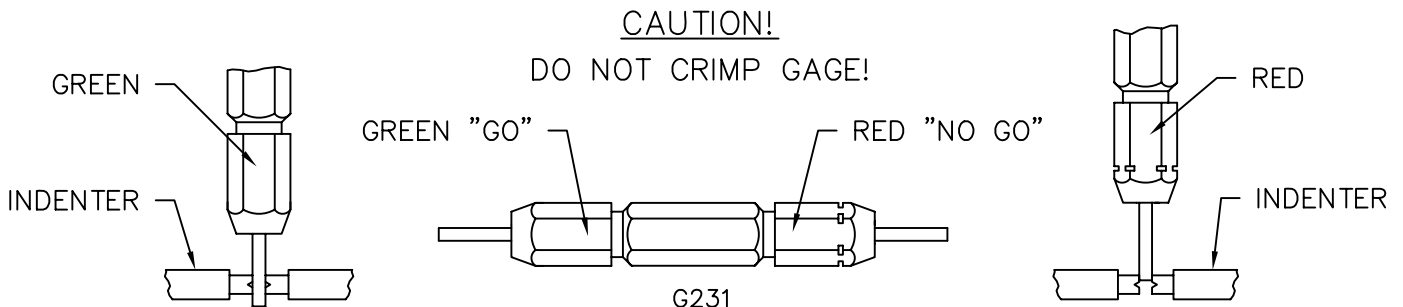

CARE OF TOOL

There It is a good practice to keep indenter tips free of residual color band deposits and other debris. A small wire brush may be used for this purpose.

We strongly recommend that you:

1. DO NOT immerse tools in cleaning solution.
2. DO NOT spray oil into tool to lubricate.
3. DO NOT attempt to disassemble tool or make repairs.

This is a precision hand crimp tool and should be handled as such.

DMC offers complete refurbishing and recalibration services.

DMC specially engineers and manufactures complete tool kits to satisfy individual customer requirements, such as total aircraft support, general shop maintenance or production, on board ship and vehicle service, etc.

LIMITATION OF LIABILITY

DANIELS MANUFACTURING CORPORATION IS NOT LIABLE FOR CONSEQUENTIAL OR SPECIAL DAMAGES OF ANY NATURE OR KIND RESULTING FROM THE USE, OR MISUSE, OF ANY OF ITS PRODUCTS. OWNERS AND USERS OF DMC PRODUCTS ASSUME FULL RESPONSIBILITY FOR INSTRUCTING THEIR EMPLOYEES IN THE PROPER AND SAFE USE OF SUCH PRODUCTS.

LIMITED WARRANTY

DMC (Daniels Manufacturing Corporation) warrants each new product sold by it to be free from defects in material and workmanship under normal use and service. DMC's obligation under this warranty is limited to the free correction or, at DMC's option, the refund of the purchase price of any such product which proves defective in normal service within ninety (90) days after delivery to the first user, provided that the product is returned to DMC with all transportation charges prepaid and which shall appear to DMC's satisfaction, after DMC's inspection, to have been defective in material or workmanship, it being understood that DMC products are not consumer products. This warranty shall not cover any damage to any product which, in the opinion of DMC, was caused by normal wear, misuse, improper operation, tampering, neglect or accident. This warranty is in lieu of all other warranties express or implied. No warranty, express or implied, is made or authorized to be made or assumed with respect to products of Daniels Manufacturing Corporation other than those herein set forth.