

8	.068	.073
7	.059	.064
6	.052	.057
5	.045	.050
4	.039	.044
3	.036	.041
2	.032	.037
1	.028	.033

SEL NO.	GO DIA	NO GO DIA
GAGING LIMITS OF INDENTERS		

USE GAGE P/N G125 AT SELECTOR NUMBER 4.

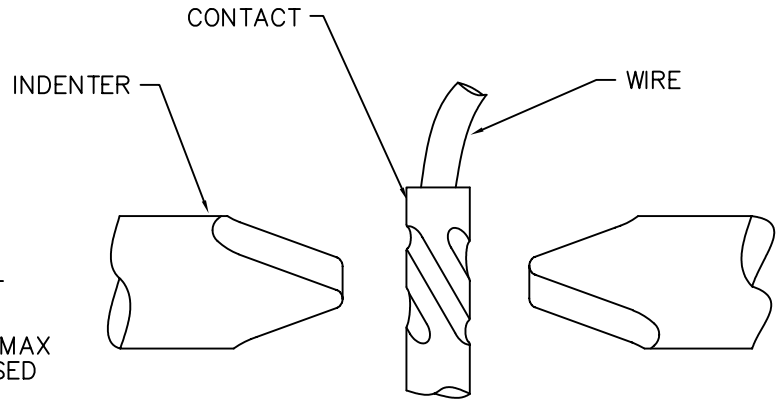
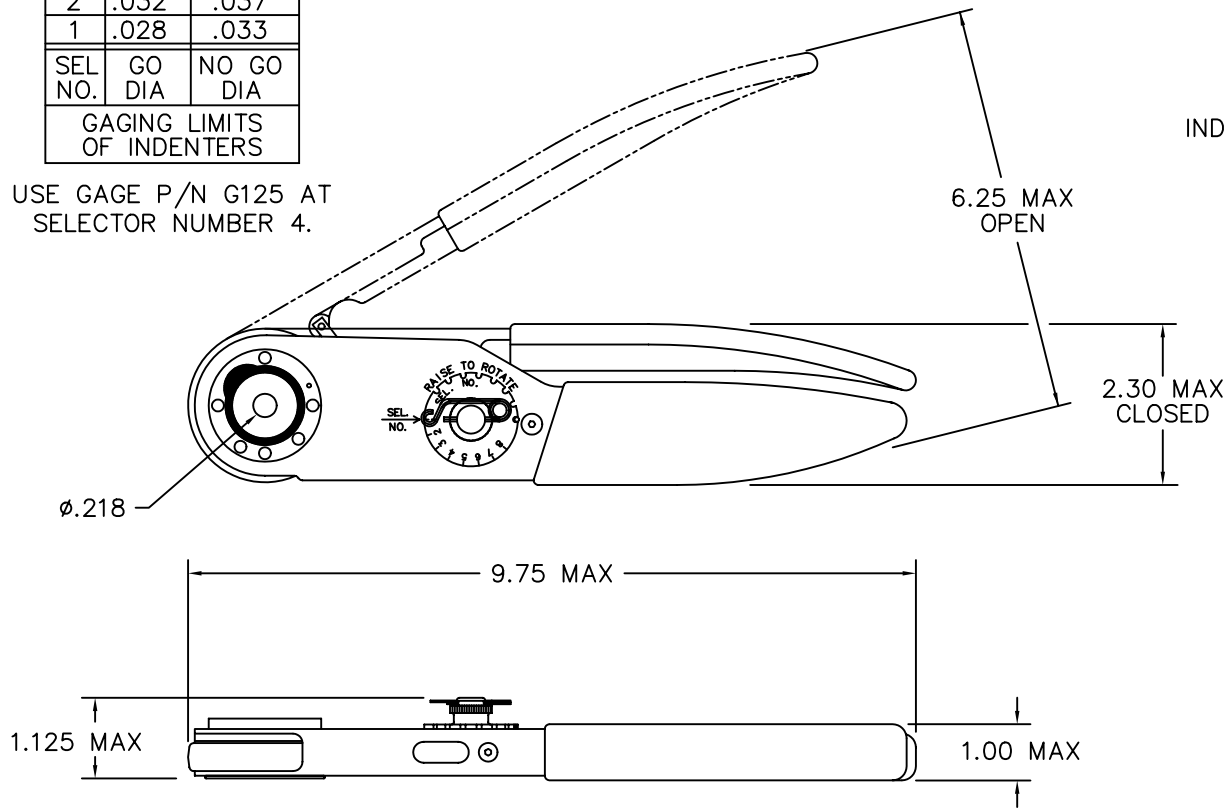

REVISIONS				
REV. SYM.	E.C.O. NUMBER	DESCRIPTION	BY DATE	APP'D DATE
1		ORIGINAL RELEASE	A MOO-YOUNG 6-28-99	RRR 6-28-99

**UNCONTROLLED DOCUMENT
WILL NOT BE UPDATED**

2. USE ONLY POSITIONERS THAT ARE SPECIFICALLY DESIGNED FOR THIS UNIQUE APPLICATION. DAMAGE TO THE TOOL AND POSITIONER COULD OCCUR IF AN INCOMPATIBLE POSITIONER IS USED.
1. THIS TOOL PRODUCES A NON-STANDARD, SPIRAL CRIMP.

NOTES:

RESTRICTED & CONFIDENTIAL		MATERIAL	ITEM	PART NO.	QTY.	DESCRIPTION/REMARKS				
CONFIDENTIAL PROPERTY OF DANIELS MANUFACTURING CORP. NOT TO BE DISCLOSED TO OTHERS; REPRODUCED OR USED FOR ANY OTHER PURPOSE, EXCEPT AS AUTHORIZED IN WRITING BY DANIELS MANUFACTURING. MUST BE RETURNED TO DANIELS MANUFACTURING CORP. ON COMPLETION OF ORDER OR OTHER PURPOSE FOR WHICH SENT.		HEAT TREAT	DRN.	A. MOO-YOUNG	DATE	6-28-99	DMC DANIELS MANUFACTURING CORP. ORLANDO, FLORIDA FSCM 11851			
			CHK'D.	RRR	DATE	6-28-99				
			APP'D.		DATE			TITLE	CRIMP TOOL ENVELOPE DRAWING	
			APP'D.		DATE			WHERE USED:		
DO NOT SCALE DRAWING		FINISH	NOTE: THIS DRAWING IS AN OUTLINE DRAWING OF THE RESPECTIVE DMC PART NUMBER INDICATED. ACTUAL DMC PART NUMBER IS DRAWING NUMBER WITHOUT THE "-ENV" SUFFIX.				SIZE	SCALE	CAD FILE NO	SHEET OF
			B	NTS	SC8-ENV	1	1			
			POSTING	DWG. NO.	SC8-ENV	REV.	1			