

MINIATURE ADJUSTABLE HAND CRIMP TOOL MH997

THIS HAND TOOL MUST NOT BE USED IN ANY POWERED "PRESS" AS DEFINED BY OSHA CFR 1910.211 (46)

SEE REVERSE SIDE FOR IMPORTANT INFORMATION CONCERNING LIMITED WARRANTY, AND LIMITATION OF LIABILITY.

HOW TO USE DANIELS MH997 BASIC HAND CRIMP TOOL AND RELATED POSITIONERS

GENERAL INFORMATION

1. Designation MH997 refers to basic hand tool without positioners.
2. The tool has a double action ratchet. Note that the tool cannot be opened without completing the cycle.
3. The MH997 crimps both the conductor and insulation in one operation.

TOOL PREPARATION

1. Tool must be in open position.
2. Remove safety clip from positioner guide.
3. Select Positioner for contact to be crimped.
4. Insert Positioner into positioner guide and turn 90 degrees until bayonet pins lock.
5. Install safety clip into positioner guide (optional).
6. Wire size and corresponding selector number are shown on dataplate.
7. With tool still in open position, raise and rotate selector knob until number indicated on dataplate for wire size to be crimped is in line with Sel. No. arrow.

CRIMPING INSTRUCTIONS

1. Insert contact and prepared wire into indenter opening from side opposite the Positioner.
2. Squeeze handles together until ratchet releases. Handle will return to the open position. Remove crimped contact and wire.

REMOVING POSITIONER

1. Remove safety clip and reverse procedure described in step four (4) above.

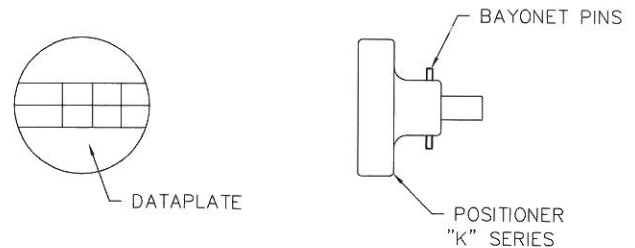
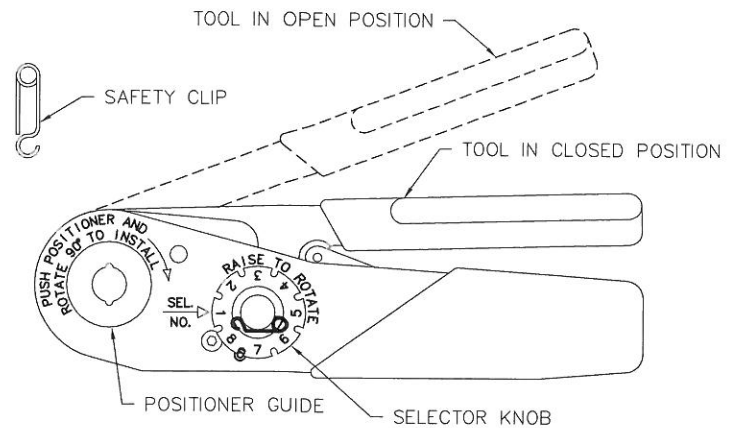

GAGE PART NO.	A GO DIA	B NO-GO DIA	SEL NO
G125	.0390	.0440	8

CAUTION!
DO NOT CRIMP GAGE!

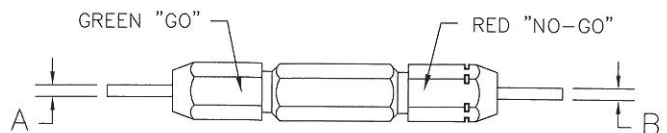

M22520/3-1

GAGING LIMITS

SELECTOR NUMBER	A $\pm .0001$ GO DIA	B $\pm .0001$ NO-GO DIA
1	.0130	.0180
2	.0160	.0210
3	.0190	.0240
4	.0220	.0270
5	.0260	.0310
6	.0300	.0350
7	.0340	.0390
8	.0390	.0440

GAGING INSTRUCTIONS

"GO" GAGING

Operate tool to fully closed position. Maintain firm hand pressure on the tool handles. Insert "GO" gage end as shown. Gage must pass freely between indenter tips.

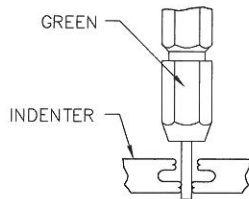

NOTE: Tool gaging must be checked between the long tips (conductor crimp) of indenters.

"NO-GO" GAGING

Operate tool to fully closed position. Maintain firm hand pressure on the tool handles. Insert "NO-GO" gage end as shown. The "NO-GO" gage may partially enter the indenter opening, but must not pass completely through the opening.

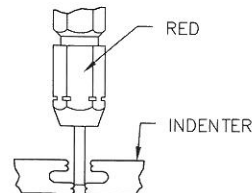

CARE OF TOOL

There is virtually no maintenance required. However, it is a good practice to keep indenter tips free of residual color band deposits and other debris. A small wire brush may be used for this purpose.

We strongly recommend that you:

1. DO NOT immerse tool in cleaning solution.
2. DO NOT spray oil into tool to lubricate.
3. DO NOT attempt to disassemble tool or make repairs.

This is a precision crimp tool and should be handled as such.

DMC offers complete refurbishing and recalibration services.

DMC specially engineers and manufactures complete tool kits to satisfy individual customer requirements, such as total aircraft support, general shop maintenance or production, on board ship and vehicle service, etc.

LIMITATION OF LIABILITY

DANIELS MANUFACTURING CORPORATION IS NOT LIABLE FOR CONSEQUENTIAL OR SPECIAL DAMAGES OF ANY NATURE OR KIND RESULTING FROM THE USE, OR MISUSE, OF ANY OF ITS PRODUCTS. OWNERS AND USERS OF DMC PRODUCTS ASSUME FULL RESPONSIBILITY FOR INSTRUCTING THEIR EMPLOYEES IN THE PROPER AND SAFE USE OF SUCH PRODUCTS.

LIMITED WARRANTY

DMC (Daniels Manufacturing Corporation) warrants each new product sold by it to be free from defects in material and workmanship under normal use and service. DMC's obligation under this warranty is limited to the free correction or, at DMC's option, the refund of the purchase price of any such product which proves defective in normal service within ninety (90) days after delivery to the first user, provided that the product is returned to DMC with all transportation charges prepaid and which shall appear to DMC's satisfaction, after DMC's inspection, to have been defective in material or workmanship, it being understood that DMC products are not consumer products. This warranty shall not cover any damage to any product which, in the opinion of DMC, was caused by normal wear, misuse, improper operation, tampering, neglect or accident. This warranty is in lieu of all other warranties express or implied. No warranty, express or implied, is made or authorized to be made or assumed with respect to products of Daniels Manufacturing Corporation other than those herein set forth.