

REVISIONS						
REV	ECO NO.	DESCRIPTION	BY	DATE	APP'D BY	DATE
3		REDRAWN	AAM	11/3/1999	RRR	11/3/1999
4	26234	UPDATED AND REDRAWN	TonyD	10/1/2020		

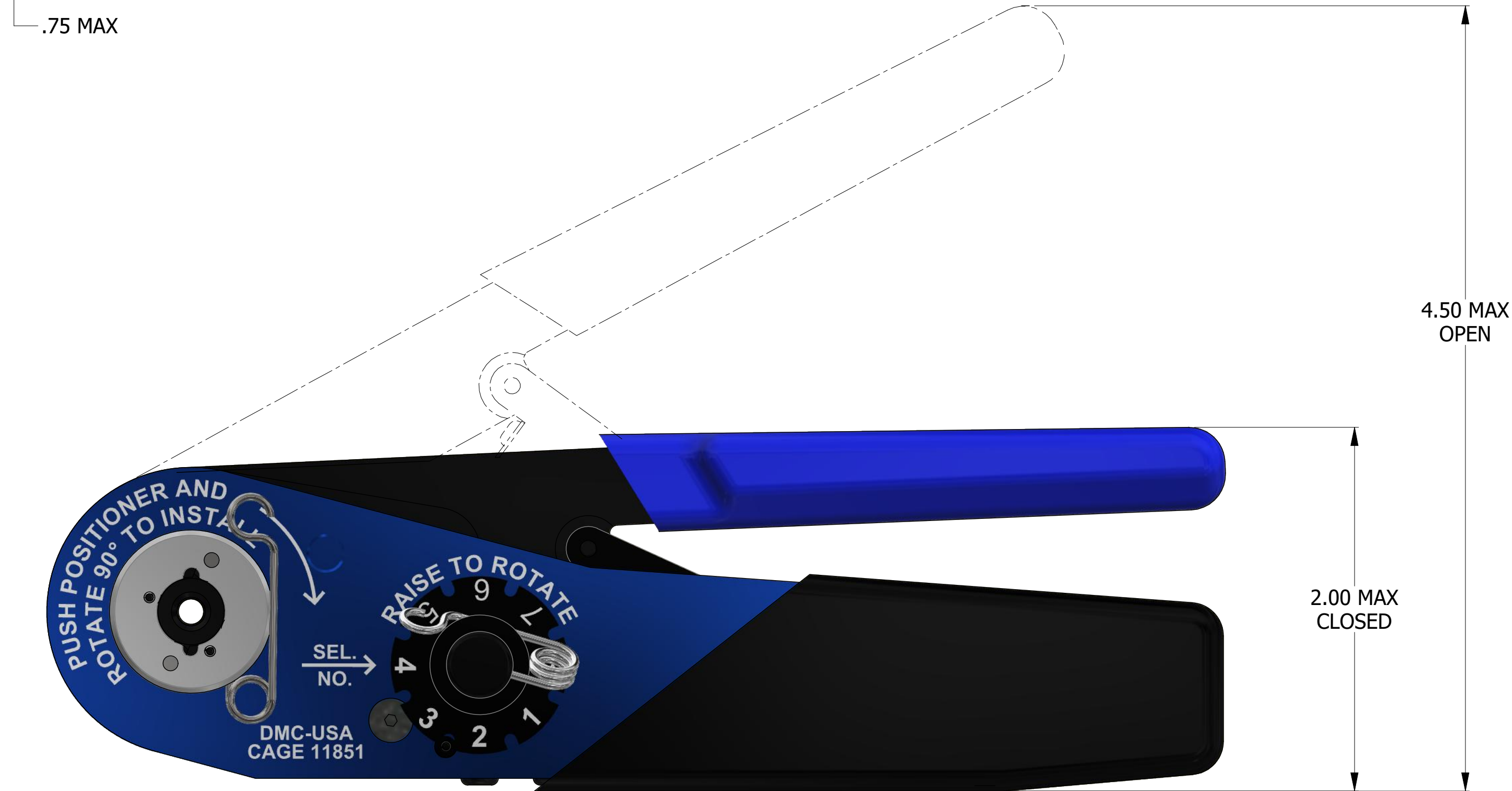
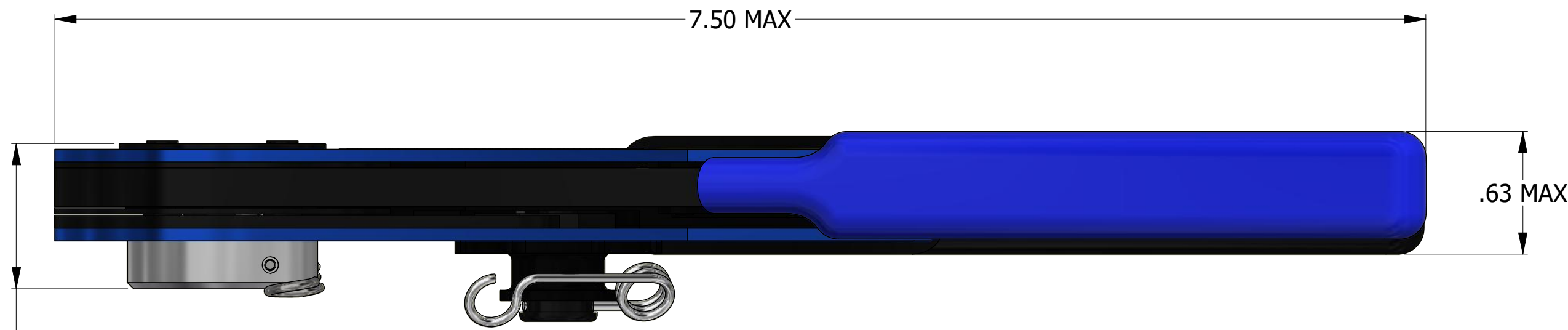

GAGING LIMITS OF INDENTERS		
SEL NO	INSPECTION GAGE	
	Ø GO ±.0001	Ø NO-GO ±.0001
1	.0070	.0090
2	.0095	.0115
3	.0120	.0140
4	.0150	.0170
5	.0180	.0200
6	.0225	.0250
7	.0260	.0285
8	.0305	.0330

CHECK WITH GAGE: G822 SEL #8

**UNCONTROLLED DOCUMENT
WILL NOT BE UPDATED**

DIMENSIONS IN INCHES - UNLESS OTHERWISE SPECIFIED

RESTRICTED & CONFIDENTIAL
CONFIDENTIAL PROPERTY OF DANIELS MANUFACTURING CORP. NOT TO BE DISCLOSED TO OTHERS, REPRODUCED OR USED FOR ANY OTHER PURPOSE EXCEPT AS AUTHORIZED IN WRITING BY DANIELS MANUFACTURING. MUST BE RETURNED TO DANIELS MANUFACTURING CORP. ON COMPLETION OF ORDER OR PURPOSES FOR WHICH LENT.

CREATED FROM AN INVENTOR MODEL.
CHANGES MUST BE REFLECTED IN THE 3D PART

DO NOT SCALE DRAWING

MATERIAL	ITEM	PART NO.	QTY.	DESCRIPTION / REMARKS
N/A	DRN. TS CHK'D. DATE	DATE 9/29/1989 DATE		DMC DANIELS MANUFACTURING CORP. ORLANDO, FLORIDA CAGE 11851
HEAT TREAT	NOTE: THIS DRAWING IS AN OUTLINE DRAWING OF THE RESPECTIVE DMC PART NUMBER INDICATED. ACTUAL DMC PART NUMBER IS CAD PART NUMBER WITHOUT THE "-ENV" SUFFIX		TITLE CRIMP TOOL ENVELOPE DRAWING	
FINISH	WHERE USED:	SIZE C	SCALE 1.75X	CAD P/N MH992-ENV DWG. NO. MH992
				SHEET 1 OF 1 REV. 4