

REVISIONS						
REV	ECO NO.	DESCRIPTION	BY	DATE	APP'D BY	DATE
1		ORIGINAL RELEASE	AAM	12/12/2001	RRR	12/12/2001
2	24210	UPDATED AND REDRAWN	TonyD	3/25/2016		

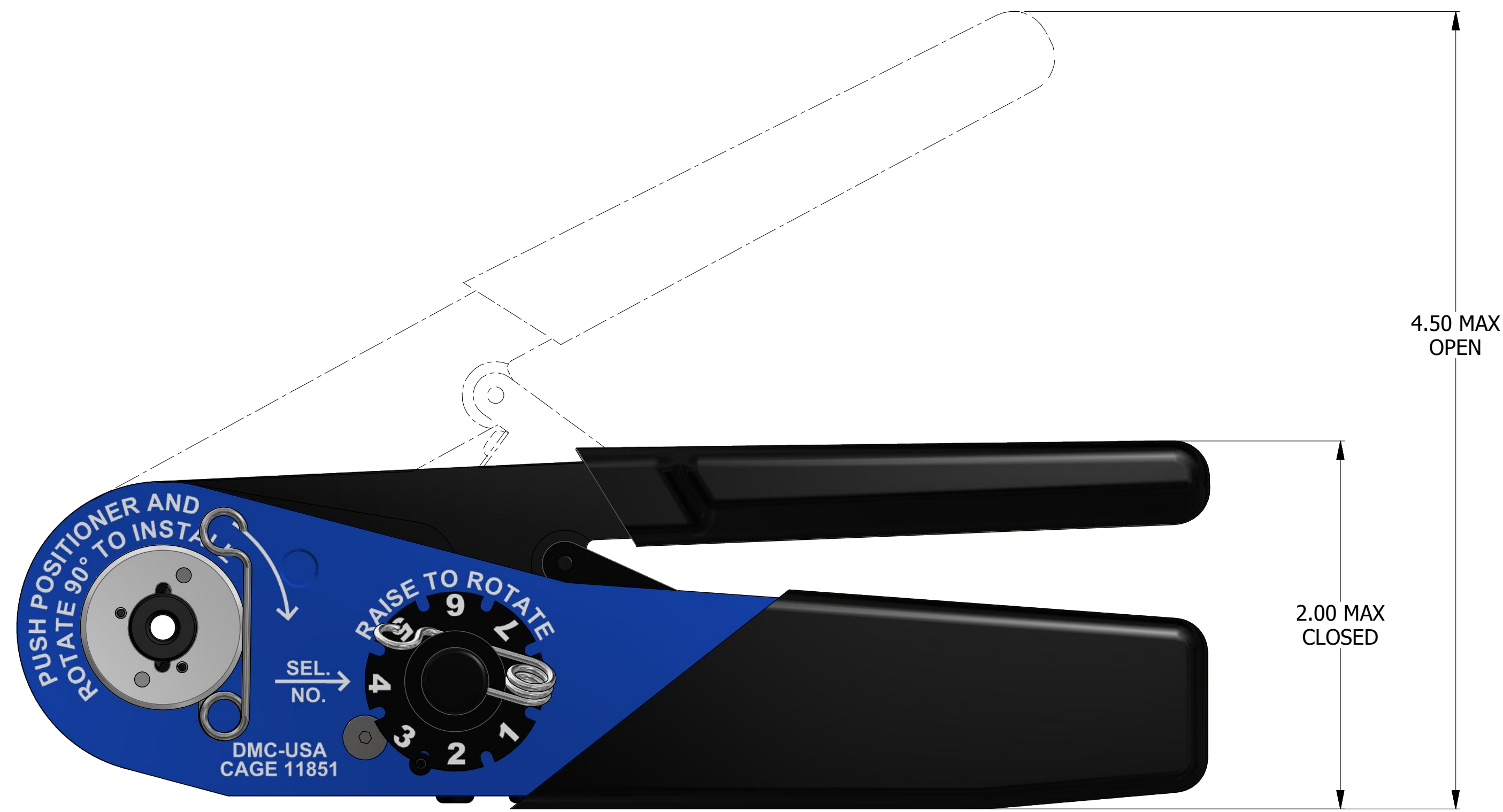
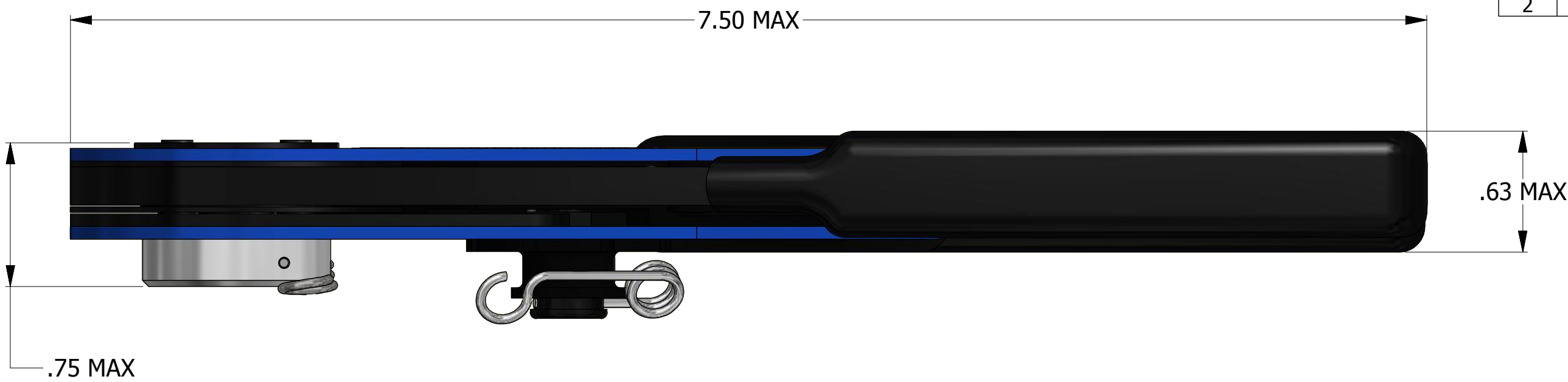

GAGING LIMITS OF INDENTERS		
SEL NO	INSPECTION GAGE	
	Ø GO ±.0001	Ø NO-GO ±.0001
1	.0070	.0090
2	.0095	.0115
3	.0120	.0140
4	.0150	.0170
5	.0180	.0200
6	.0225	.0250
7	.0260	.0285
8	.0305	.0330

CHECK WITH GAGE: G822 SEL #8

**UNCONTROLLED DOCUMENT
WILL NOT BE UPDATED**
DIMENSIONS IN INCHES - UNLESS OTHERWISE SPECIFIED

RESTRICTED & CONFIDENTIAL
CONFIDENTIAL PROPERTY OF DANIELS MANUFACTURING CORP. NOT TO BE DISCLOSED TO OTHERS. REPRODUCTION OR USED FOR ANY OTHER PURPOSE EXCEPT AS AUTHORIZED IN WRITING BY DANIELS MANUFACTURING. MUST BE RETURNED TO DANIELS MANUFACTURING CORP. ON COMPLETION OF ORDER OR PURPOSES FOR WHICH LENT.
CREATED FROM AN INVENTOR MODEL. CHANGES MUST BE REFLECTED IN THE 3D PART
DO NOT SCALE DRAWING

MATERIAL	ITEM	PART NO.	QTY.	DESCRIPTION / REMARKS
N/A	DRN. AAM CHK'D.	DATE 12/12/2001 DATE		DMC DANIELS MANUFACTURING CORP. ORLANDO, FLORIDA CAGE 11851
HEAT TREAT N/A	NOTE: THIS DRAWING IS AN OUTLINE DRAWING OF THE RESPECTIVE DMC PART NUMBER INDICATED. ACTUAL DMC PART NUMBER IS CAD PART NUMBER WITHOUT THE "-ENV" SUFFIX		TITLE CRIMP TOOL ENVELOPE DRAWING	
FINISH N/A	SIZE C	SCALE 1.75X	CAD P/N MH835-ENV DWG. NO. MH835	SHEET 1 OF 1 REV. 2