

REVISIONS				
REV. SYM.	E.C.O. NUMBER	DESCRIPTION	BY DATE	APP'D DATE
3		UPDATED TITLE	ENF 1-13-11	

GAGING LIMITS FOR INDENTERS

SELECTOR NO.	GAGE-INSPECTION	
	GO DIA ±.0001	NO-GO DIA ±.0001
1	.0430	.0460
2	.0460	.0490
3	.0490	.0520
4	.0520	.0550
5	.0560	.0590
6	.0600	.0630
7	.0640	.0670
8	.0690	.0720

USE GAGE P/N G256 AT SEL NO 8

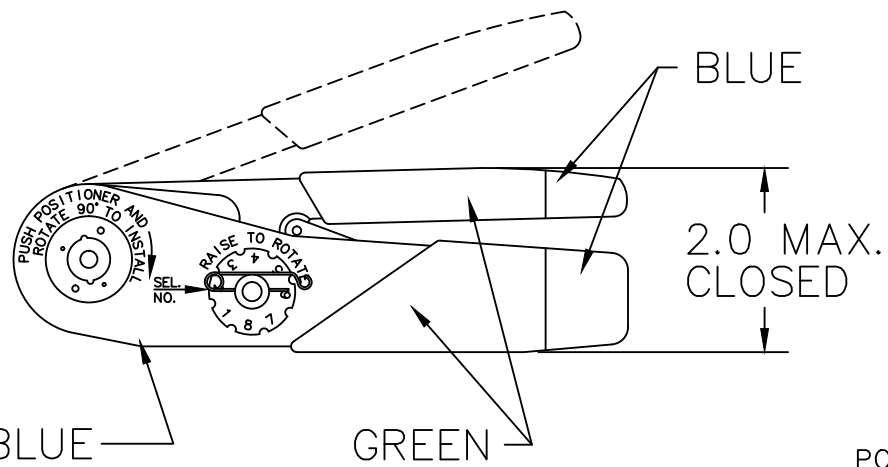

POSITIONERS USED WITH MH802

PART NUMBER	CONTACTS ACCOMMODATED
D16/1-1M	M39029/19-01 M39029/21/01 INNER SHD SLEEVES A & B
D16/2-1M	M39029/20-01 INNER SHD SLEEVES A & B

GAGING LIMITS FOR RETAINERS

SELECTOR NO.	GAGE-INSPECTION	
	GO DIA ±.0001	NO-GO DIA ±.0001
8	.0740	.0770

USE GAGE P/N G258 AT SEL NO 8

**UNCONTROLLED DOCUMENT  
WILL NOT BE UPDATED**  
DIMENSIONS IN INCHES - UNLESS OTHERWISE SPECIFIED

CONFORMS TO REF:  
M22520/20-01  
MEETS PERFORMANCE  
STANDARD,  
BUT IS NOT QPL

**RESTRICTED & CONFIDENTIAL**

CONFIDENTIAL PROPERTY OF DANIELS MANUFACTURING CORP. NOT TO BE DISCLOSED TO OTHERS, REPRODUCED OR USED FOR ANY OTHER PURPOSE, EXCEPT AS AUTHORIZED IN WRITING BY DANIELS MANUFACTURING. MUST BE RETURNED TO DANIELS MANUFACTURING CORP. ON COMPLETION OF ORDER OR OTHER PURPOSE FOR WHICH LENT.

DO NOT SCALE DRAWING

DRN.	J. JOYCE	DATE	2/13/03
CHK'D.	RRR	DATE	2/13/03
APP'D.		DATE	
APP'D.		DATE	



DANIELS MANUFACTURING CORP.  
ORLANDO, FLORIDA  
CAGE 11851

TITLE				ENVELOPE DRAWING CRIMP TOOL			
WHERE USED:							
SIZE	SCALE	CAD P/N		SHEET		OF	
A	NTS	MH802-ENV		1		1	
POSTING		P/N		REV.			
		MH802-ENV		3			