

ADJUSTABLE HAND CRIMP TOOL M322

DMC DANIELS
MANUFACTURING
CORPORATION
DATASHEET

THIS HAND TOOL MUST NOT BE USED IN ANY POWERED "PRESS" AS DEFINED BY OSHA CFR 1910.211 (46)

SEE REVERSE SIDE FOR IMPORTANT INFORMATION CONCERNING LIMITED WARRANTY, AND LIMITATION OF LIABILITY.

HOW TO USE THE DANIELS M322 HAND CRIMP TOOL & POSITIONER

GENERAL INFORMATION

1. The tool has a double action ratchet. Note that the tool cannot be opened without completing the cycle.
2. Designation M322 refers to the basic hand tool without positioners.
3. Size: 9.75" x 2.5" x 1.25" Weight: 15oz.

SETTING UP INSTRUCTIONS

1. Tool must be in the open position.
2. Place selected Single Position Head assembly onto retainer ring with alignment pin in alignment hole.
3. After Single Position Head is seated against retainer ring, tighten socket head screws with 9/64 inch hex key.
4. Refer to dataplate on Single Position Head. From the proper wire size column, determine the selector number that corresponds with the contact being used.
5. Remove Spring Clip from selector knob. Raise selector knob and rotate until selector number is in line with index mark. Replace Spring Clip (optional).

CRIMPING INSTRUCTIONS

1. Insert contact and prepared wire through the indenter opening into Positioner.
2. Squeeze handles together until ratchet releases. Handle will return to open position. Remove crimped contact and wire.

REMOVING SINGLE POSITION HEAD

1. Loosen socket head screws until threads are disengaged from retainer ring, then remove with a straight lifting motion.

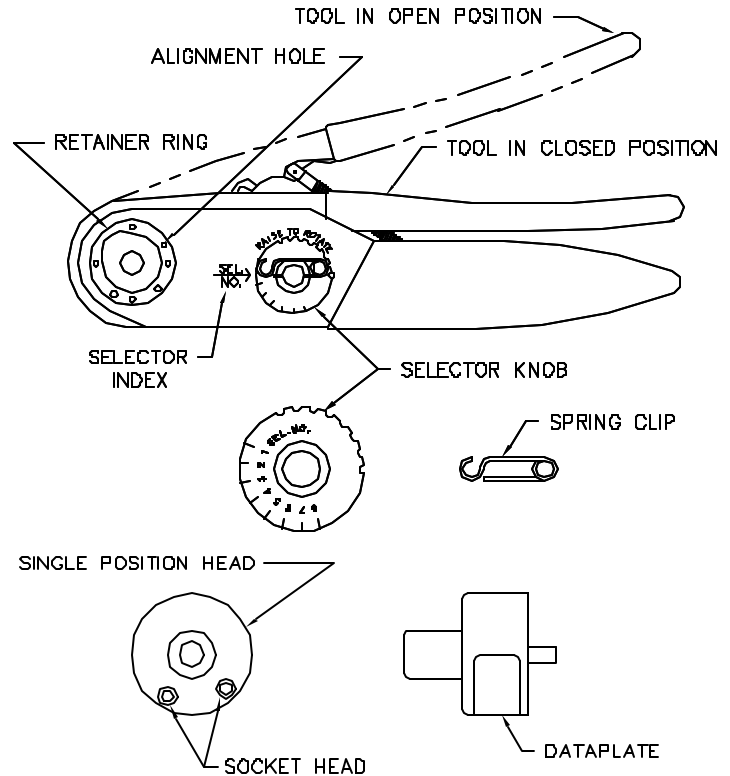

GAGE PART NO.	A GO DIA	B NO-GO DIA	SEL NO
G795	.1080	.1130	4

CAUTION!
DO NOT CRIMP GAGE!

Only one gage is necessary for periodic inspection.

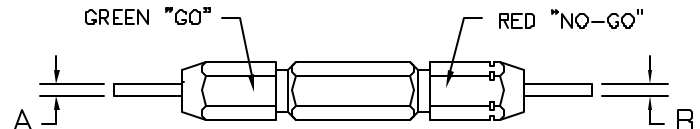

GAGING INSTRUCTIONS

"GO" GAGING

Operate tool to fully closed position. Maintain firm hand pressure on the tool handles. Insert "GO" gage end as shown. Gage must pass freely between indenter tips.

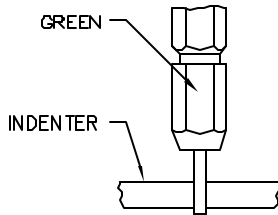

"NO-GO" GAGING

Operate tool to fully closed position. Maintain firm hand pressure on the tool handles. Insert "NO-GO" gage end as shown. The "NO-GO" gage may partially enter the indenter opening, but must not pass completely through the opening.

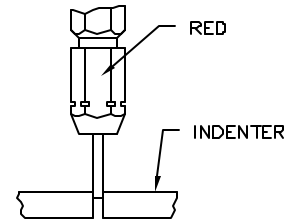

GAGING LIMITS

SELECTOR NUMBER	A $\pm .0001$ GO DIA	B $\pm .0001$ NO-GO DIA
1	.0830	.0880
2	.0920	.0970
3	.0990	.1040
4	.1080	.1130
5	.1160	.1210
6	.1230	.1280
7	.1330	.1380
8	.1470	.1520

CARE OF TOOL

There is virtually no maintenance required. However, it is a good practice to keep indenter tips free of residual color band deposits and other debris. A small wire brush may be used for this purpose.

We strongly recommend that you:

1. DO NOT immerse tools in cleaning solution.
2. DO NOT spray oil into tool to lubricate.
3. DO NOT attempt to disassemble tool or make repairs.

This is a precision hand crimp tool and should be used as such.

DMC offers complete refurbishing and recalibration services.

DMC specially engineers and manufactures complete tool kits to satisfy individual customer requirements, such as total aircraft support, general shop maintenance or production, on board ship and vehicle service, etc.

LIMITATION OF LIABILITY

DANIELS MANUFACTURING CORPORATION IS NOT LIABLE FOR CONSEQUENTIAL OR SPECIAL DAMAGES OF ANY NATURE OR KIND RESULTING FROM THE USE, OR MISUSE, OF ANY OF ITS PRODUCTS. OWNERS AND USERS OF DMC PRODUCTS ASSUME FULL RESPONSIBILITY FOR INSTRUCTING THEIR EMPLOYEES IN THE PROPER AND SAFE USE OF SUCH PRODUCTS.

LIMITED WARRANTY

DMC (Daniels Manufacturing Corporation) warrants each new product sold by it to be free from defects in material and workmanship under normal use and service. DMC's obligation under this warranty is limited to the free correction or, at DMC's option, the refund of the purchase price of any such product which proves defective in normal service within ninety (90) days after delivery to the first user, provided that the product is returned to DMC with all transportation charges prepaid and which shall appear to DMC's satisfaction, after DMC's inspection, to have been defective in material or workmanship, it being understood that DMC products are not consumer products. This warranty shall not cover any damage to any product which, in the opinion of DMC, was caused by normal wear, misuse, improper operation, tampering, neglect or accident. This warranty is in lieu of all other warranties express or implied. No warranty, express or implied, is made or authorized to be made or assumed with respect to products of Daniels Manufacturing Corporation other than those herein set forth.