

REV. SYM.		E.C.O. NUMBER		DESCRIPTION		BY DATE		APPD DATE	
1				ORIGINAL RELEASE		AAM	3-2-01	RRR	3-2-01

**UNCONTROLLED DOCUMENT
WILL NOT BE UPDATED**
DIMENSIONS IN INCHES - UNLESS OTHERWISE SPECIFIED

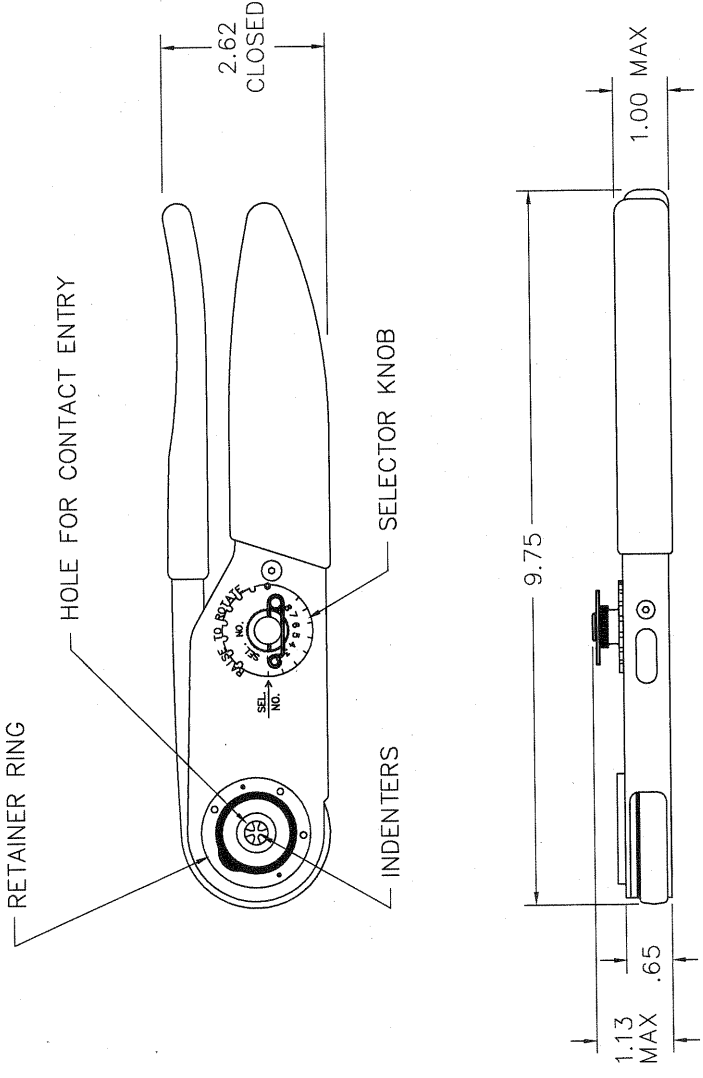

GAGING LIMITS OF INDENTERS

SELECTOR NUMBER	GAGE-INSPECTION	
	GO DIA	NO. GO DIA
1	.0700	.0800
2	.0750	.0850
3	.0800	.0900
4	.0850	.0950
5	.0920	.1020
6	.0990	.1090
7	.1080	.1180
8	.1180	.1280

USE GAGE P/N G394 AT SELECTOR NUMBER 4.

ITEM	DRN.	CHK'D.	APP'D.	APP'D.	PART NO.	QTY.	DESCRIPTION/REMARKS
	AAM	RRR					DMC DANIELS MANUFACTURING CORP. ORLANDO, FLORIDA GAGE 11851
							TITLE ENVELOPE DRAWING CRIMP TOOL
NOTE: THIS DRAWING IS AN OUTLINE DRAWING OF THE RESPECTIVE DMC PART NUMBER INDICATED. ACTUAL DMC PART NUMBER IS DRAWING NUMBER WITHOUT THE "-ENV" SUFFIX.							
WHERE USED: SIZE SCALE B NTS POSTING							
CAD P/N M300BTH-ENV SHEET OF 1 DWG. NO. M300BTH-ENV REV. 1							

RESTRICTED & CONFIDENTIAL
CONFIDENTIAL PROPERTY OF DANIELS MANUFACTURING CORP. NOT TO BE DISCLOSED TO OTHERS, REPRODUCED OR USED FOR ANY OTHER PURPOSE, EXCEPT AS AUTHORIZED IN WRITING BY DANIELS MANUFACTURING. MUST BE RETURNED TO DANIELS MANUFACTURING UPON COMPLETION OF ORDER OR OTHER PURPOSE FOR WHICH LENT.

DO NOT SCALE DRAWING

- THE OPENING FOR CONTACT ENTRY HAS A DIAMETER OF .337.
- USE ONLY WITH POSITIONERS THAT ARE SPECIFICALLY DESIGNED FOR THE M300BTH CRIMP TOOL.

NOTES: