

REVISIONS				
REV. SYM.	E.C.O. NUMBER	DESCRIPTION	BY DATE	APP'D DATE
1		ORIGINAL RELEASE	AAM 10-9-00	RRR 10-9-00

**UNCONTROLLED DOCUMENT  
WILL NOT BE UPDATED**

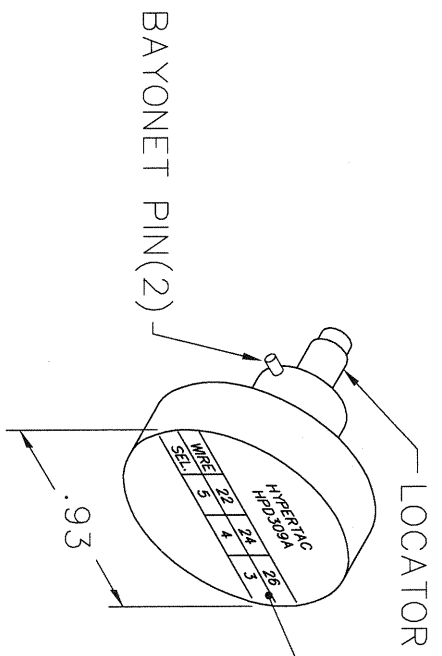
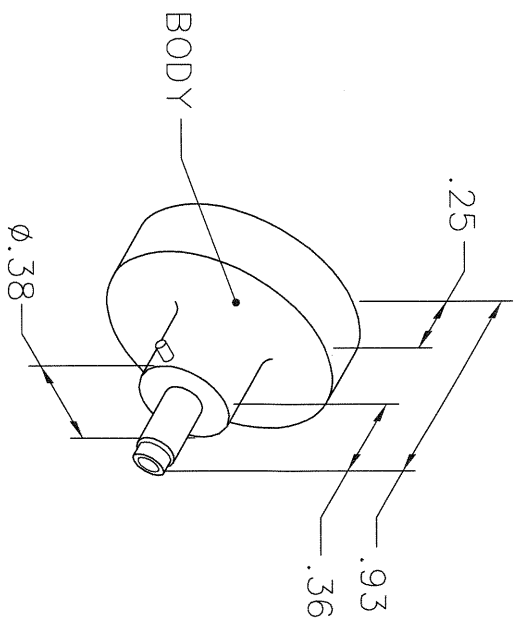

HYPERTAC			
HPD309A			
WIRE	22	24	26
SEL.	5	4	3

NOTE: FOR USE WITH DANIELS CRIMP TOOLS  
ACCOMMODATING "K" SERIES POSITIONERS

LOCATOR	ADDITIONAL FEATURES
HOLE DIMENSIONS	$\phi .101$
$\nabla .58$ MIN.	$\nabla .405$

**RESTRICTED & CONFIDENTIAL**

CONFIDENTIAL PROPERTY OF DANIELS MANUFACTURING CORP. NOT TO BE DISCLOSED TO OTHERS, REPRODUCED OR USED FOR ANY OTHER PURPOSE, EXCEPT AS AUTHORIZED IN WRITING BY DANIELS MANUFACTURING. MUST BE RETURNED TO DANIELS MANUFACTURING CORP. ON COMPLETION OF ORDER OR OTHER PURPOSE FOR WHICH LENT.

**DO NOT SCALE DRAWING**

DRN. AAM	DATE 10-9-00	TITLE	
CHK'D. RRR	DATE 10-9-00	ENVELOPE DRAWING POSITIONER	
APP'D.	DATE	WHERE USED: AFMB	
APP'D.	DATE	SIZE A	SCALE NTS
NOTE: THIS DRAWING IS AN OUTLINE DRAWING OF THE RESPECTIVE DMC PART NUMBER INDICATED. ACTUAL DMC PART NUMBER IS DRAWING NUMBER WITHOUT THE "-ENV" SUFFIX.		CAD P/N K869-ENV	SHEET 1 OF 1
		DWG. NO. K869-ENV	REV. 1

**DMC** DANIELS MANUFACTURING CORP.  
ORLANDO, FLORIDA  
CAGE 11851