

REVISIONS				
REV. SYM.	E.C.O. NUMBER	DESCRIPTION	BY DATE	APP'D DATE
1		ORIGINAL RELEASE	AAM 8-3-98	

**UNCONTROLLED DOCUMENT
WILL NOT BE UPDATED**

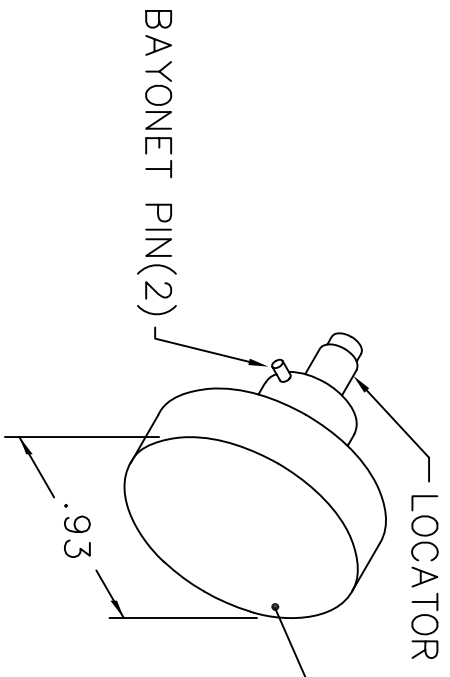
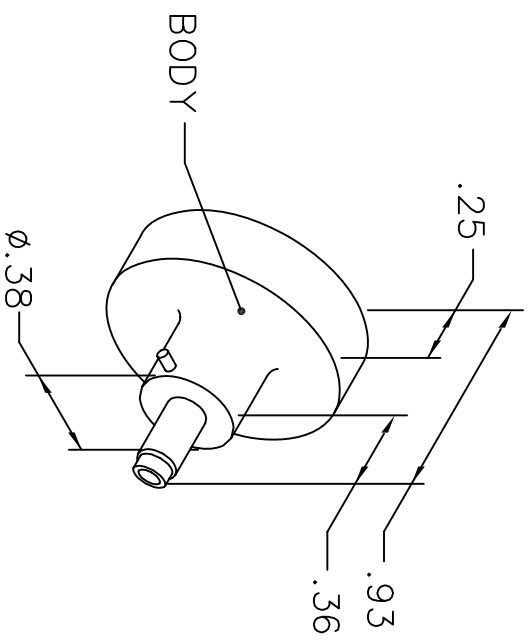

USE WITH CONTACTS

AMPHENOL 711GB SERIES				
WIRE	22	24	26	AWG
SEL.	5	4	3	

NOTE: FOR USE WITH DANIELS CRIMP TOOLS
ACCOMMODATING "K" SERIES POSITIONERS

LOCATOR	
HOLE DIMENSIONS	ADDITIONAL FEATURES
∅.027 ∅.310	<input type="checkbox"/> ∅.044 <input type="checkbox"/> ∅.276 <input type="checkbox"/> ∅.052 <input type="checkbox"/> ∅.047

RESTRICTED & CONFIDENTIAL

CONFIDENTIAL PROPERTY OF DANIELS MANUFACTURING CORP. NOT TO BE DISCLOSED TO OTHERS, REPRODUCED OR USED FOR ANY OTHER PURPOSE, EXCEPT AS AUTHORIZED IN WRITING BY DANIELS MANUFACTURING. MUST BE RETURNED TO DANIELS MANUFACTURING CORP. ON COMPLETION OF ORDER OR OTHER PURPOSE FOR WHICH LENT.

DO NOT SCALE DRAWING

DRN.	J. JOYCE	DATE	9/14/05
CHK'D.	RRR	DATE	9/14/05
APP'D.		DATE	
APP'D.		DATE	

NOTE: THIS DRAWING IS AN OUTLINE DRAWING OF THE RESPECTIVE DMC PART NUMBER INDICATED. ACTUAL DMC PART NUMBER IS DRAWING NUMBER WITHOUT THE "-ENV" SUFFIX.

WHERE USED:

SIZE	SCALE	CAD P/N	SHEET	OF
A	NTS	K757MR-ENV	1	1
POSTING		DWG. NO. K757MR-ENV		REV. 1

DMC DANIELS MANUFACTURING CORP.
ORLANDO, FLORIDA
CAGE 11851

ENVELOPE DRAWING
POSITIONER