

REVISIONS						
REV	ECO NO.	DESCRIPTION	BY	DATE	APP'D BY	DATE
1		ORIGINAL RELEASE	K. KOONS	12/9/2022		

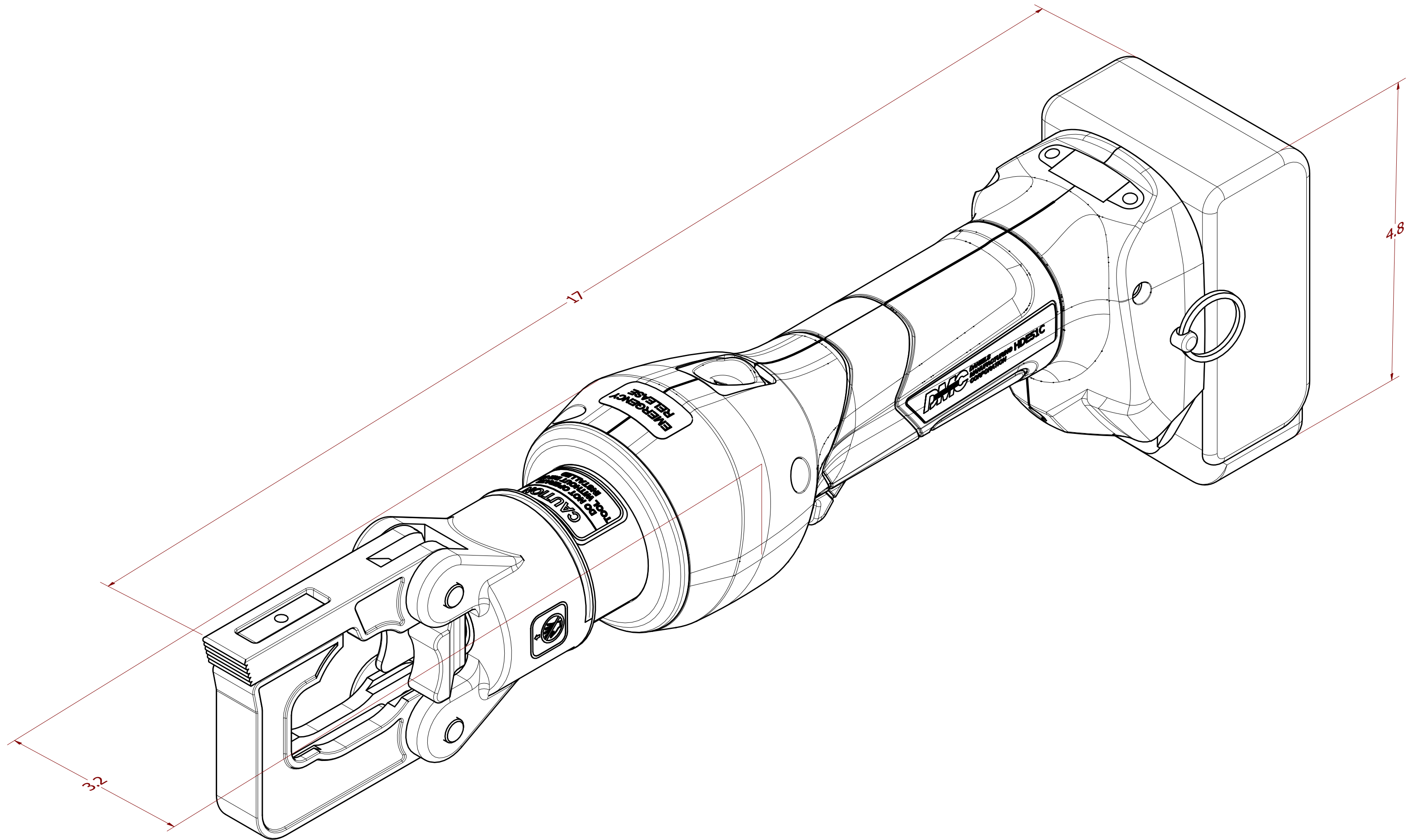

1. CRIMP FORCE = 5.5 tons
2. WEIGHT = 6.1lb
3. BATTERY POWER = 18VDC Li-ion
4. APPLICATION = DMC HD51 SERIES DIE SETS

NOTES:

**UNCONTROLLED DOCUMENT
WILL NOT BE UPDATED**
DIMENSIONS IN INCHES - UNLESS OTHERWISE SPECIFIED

RESTRICTED & CONFIDENTIAL
CONFIDENTIAL PROPERTY OF DANIELS MANUFACTURING CORP. NOT TO BE DISCLOSED TO OTHERS. REPRODUCTION OR USED FOR ANY OTHER PURPOSE EXCEPT AS AUTHORIZED IN WRITING BY DANIELS MANUFACTURING. MUST BE RETURNED TO DANIELS MANUFACTURING CORP. ON COMPLETION OF ORDER OR PURPOSES FOR WHICH LENT.

DRN. KIRK C KOONS	DATE 7/26/2022	INTERPRET PER ASME Y14.5M-2018		
CHK'D JC	DATE 7/26/2022	DANIELS MANUFACTURING CORP. ORLANDO, FLORIDA CAGE 11851		
APP'D JC	DATE 7/26/2022			
NOTE: THIS DRAWING IS AN OUTLINE DRAWING OF THE RESPECTIVE DMC PART NUMBER INDICATED.		TITLE BATTERY POWERED CRIMP TOOL ENVELOPE DRAWING		
WHERE USED:		SIZE C	SCALE N.T.S.	CAD NO. HDE51C-ENV
		PART NO. HDE51C		SHEET 1 OF 1
				REV. 1