

REVISIONS					
REV	ECO NO.	DESCRIPTION	BY	DATE	APP'D BY
1		ORIGINAL RELEASE	K. KOONS	7/14/2022	

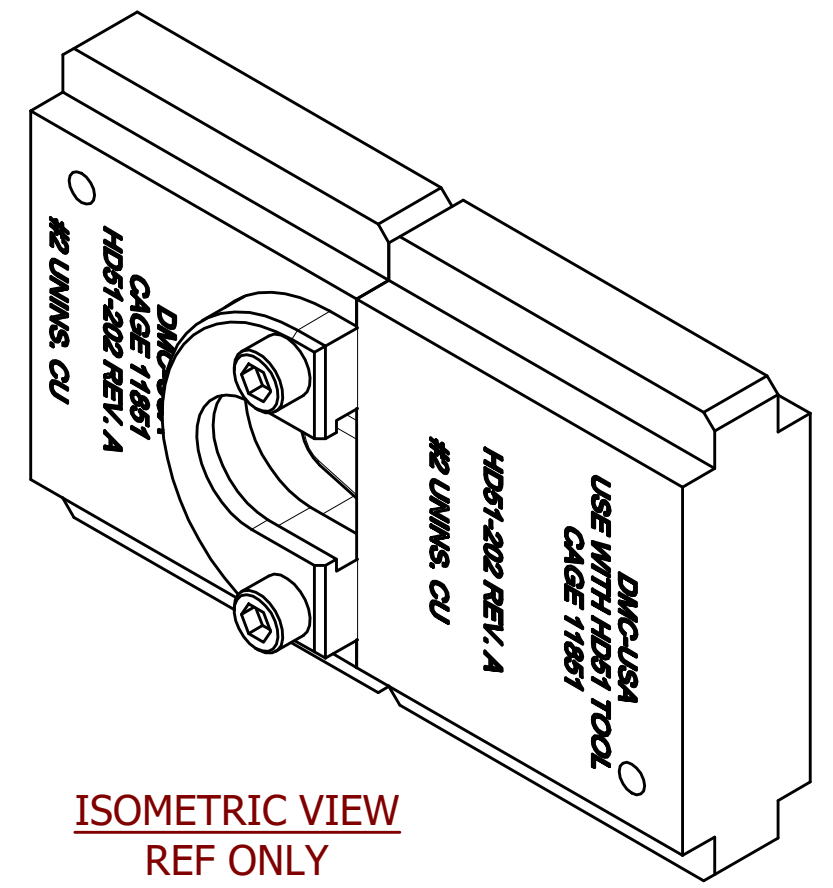
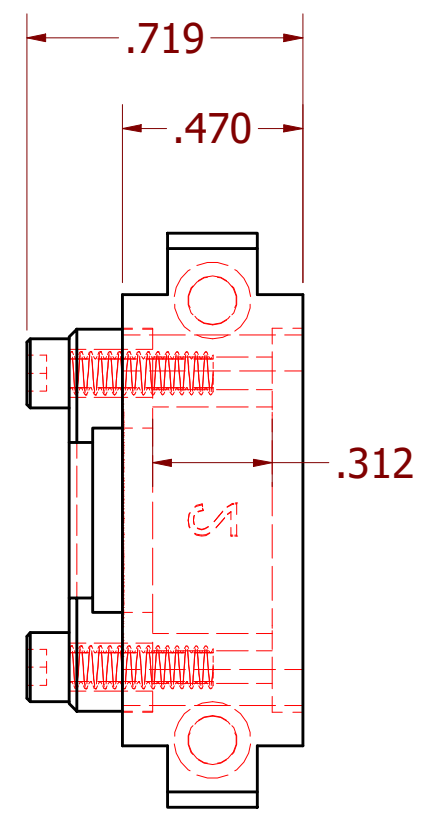
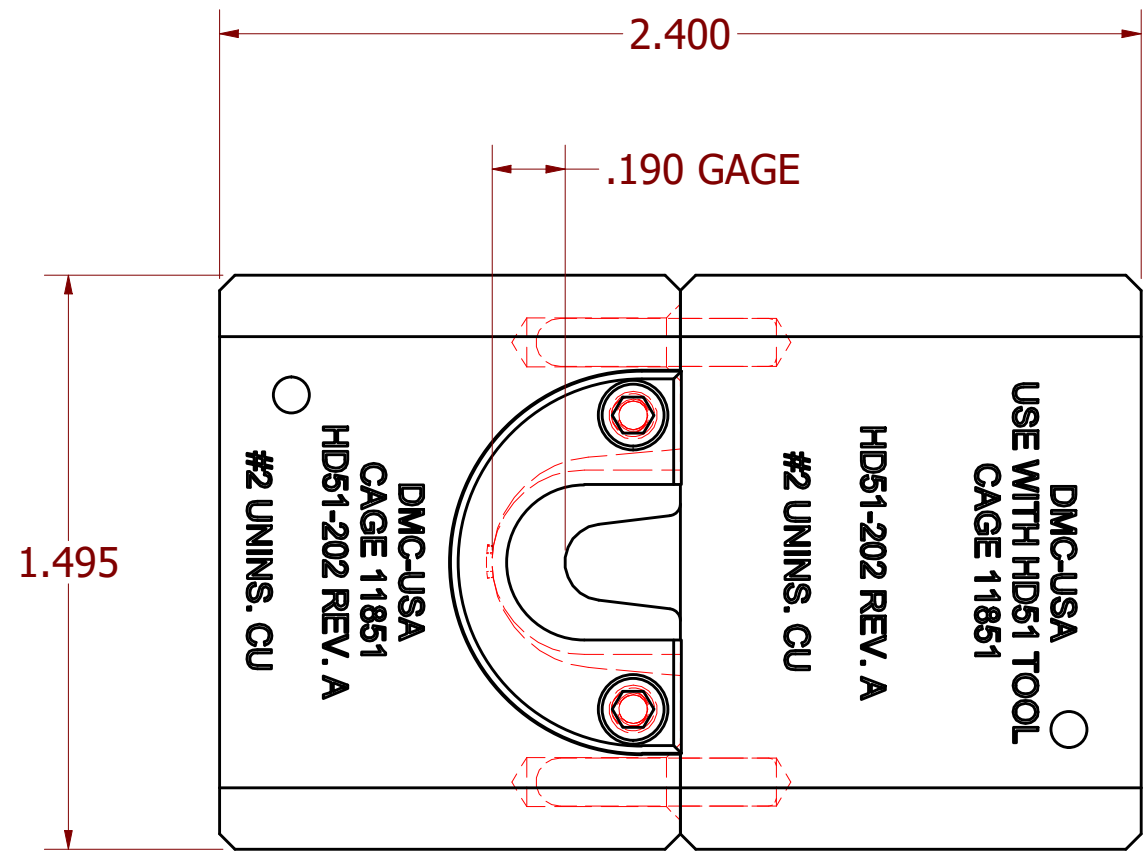

ISOMETRIC VIEW  
REF ONLY

**UNCONTROLLED DOCUMENT  
WILL NOT BE UPDATED**  
DIMENSIONS IN INCHES - UNLESS OTHERWISE SPECIFIED

NOTES:

RESTRICTED & CONFIDENTIAL  
CONFIDENTIAL PROPERTY OF DANIELS MANUFACTURING CORP. NOT TO BE DISCLOSED TO OTHERS. REPRODUCTION OR USED FOR ANY OTHER PURPOSE EXCEPT AS AUTHORIZED IN WRITING BY DANIELS MANUFACTURING. MUST BE RETURNED TO DANIELS MANUFACTURING CORP. ON COMPLETION OF ORDER OR PURPOSES FOR WHICH LENT.

DRN. KIRK C KOONS	DATE 7/27/2017	INTERPRET PER ASME Y14.5M-2018			
CHK'D TLM	DATE 7/27/2017	 <b>DANIELS MANUFACTURING CORP.</b> ORLANDO, FLORIDA CAGE 11851			
APP'D	DATE				
NOTE: THIS DRAWING IS AN OUTLINE DRAWING OF THE RESPECTIVE DMC PART NUMBER INDICATED.		TITLE SINGLE INDENT, #2AWG UNINSULATED ENVELOPE DRAWING  WHERE USED:			
SIZE B	SCALE N.T.S.	CAD NO. HD51-202-ENV	SHEET 1 OF 1		REV. 1
		PART NO. HD51-202			