

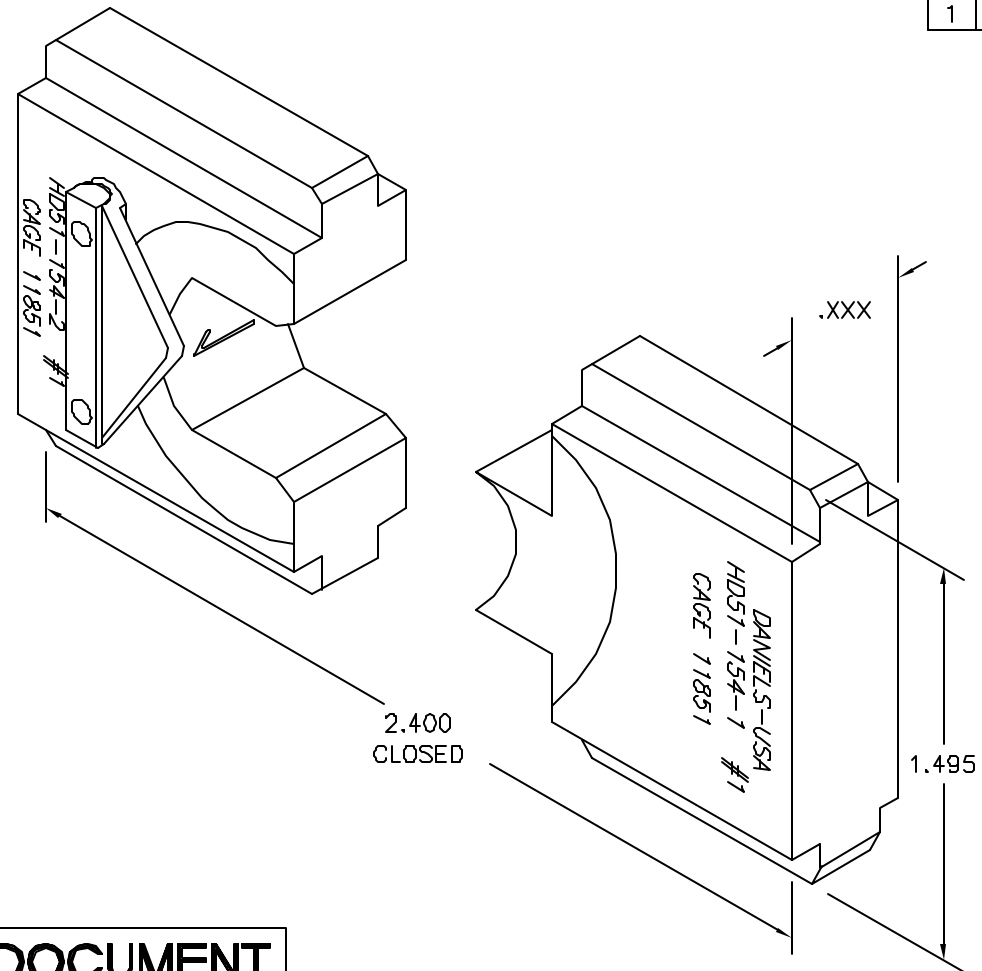

REVISIONS				
REV. STN.	E.C.Q. NUMBER	DESCRIPTION	BY DATE	APP'D DATE
1		ORIGINAL RELEASE	JWJ 3/18/03	RRR 3/18/03



**UNCONTROLLED DOCUMENT
WILL NOT BE UPDATED**

2. GAGING DIM: $.339 \pm .002$ - CHECK WITH GAGE G726.
 1. EQUIVALENT TO MS23002-1; FOR USE WITH MS25036 SIZE 1.

NOTES:

RESTRICTED & CONFIDENTIAL CONFIDENTIAL PROPERTY OF DANIELS MANUFACTURING CORP. NOT TO BE DISCLOSED TO OTHERS, REPRODUCED OR USED FOR ANY OTHER PURPOSE, EXCEPT AS AUTHORIZED IN WRITING BY DANIELS MANUFACTURING. MUST BE RETURNED TO DANIELS MANUFACTURING CORP. ON COMPLETION OF ORDER OR OTHER PURPOSE FOR WHICH LENT.	MATERIAL	ITEM	PART NO.	QTY.	DESCRIPTION/REMARKS	
	HEAT TREAT	DRN	J. JOYCE	DATE	 DANIELS MANUFACTURING CORP. ORLANDO, FLORIDA CAGE 11851	
	FINISH	CHK'D	RRR	DATE		TITLE
		APP'D		DATE		DIE SET #1 ENVELOPE DRAWING
DO NOT SCALE DRAWING		APP'D		DATE		WHERE USED:
					SIZE B SCALE NTS CAD P/N HD51-154-ENV SHEET 1 OF 1 POSTING DWG. NO. HD51-154-ENV REV. 1	

NOTE:
 THIS DRAWING IS AN OUTLINE DRAWING OF THE RESPECTIVE DMC PART NUMBER INDICATED. ACTUAL DMC PART NUMBER IS DRAWING NUMBER WITHOUT THE "-ENV" SUFFIX.