

REVISIONS				
REV. NUMBER	E.C.O. NUMBER	DESCRIPTION	BY DATE DATE	APP'D DATE
1		ORIGINAL RELEASE	RRR 3-17-00	RRR 3-17-00

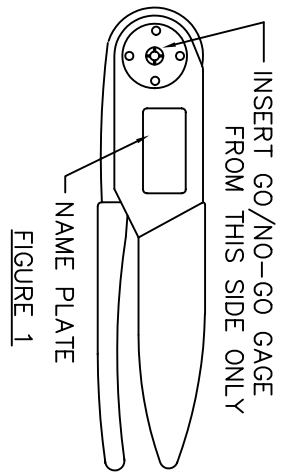
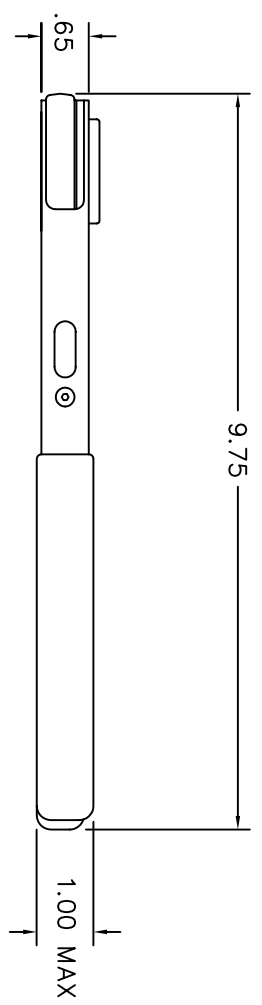
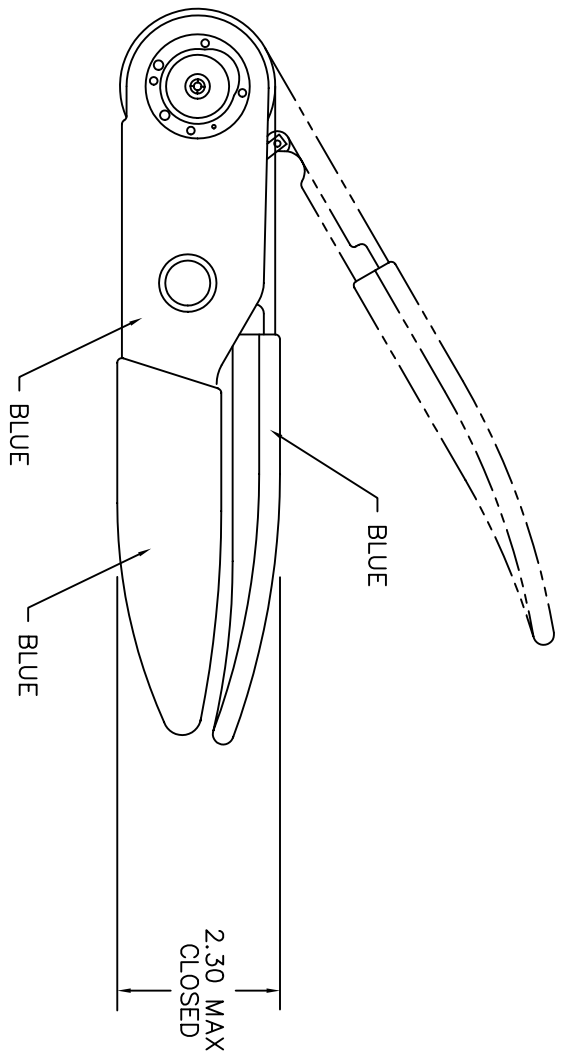

- USE GAGE P/N G533.
- GAGING DIMENSIONS (FIGURE 1):
GO .197 / NO-GO .201.

NOTES:

**UNCONTROLLED DOCUMENT
WILL NOT BE UPDATED**

RESTRICTED & CONFIDENTIAL
CONFIDENTIAL PROPERTY OF DANIELS MANUFACTURING CORP. NOT TO BE DISCLOSED TO OTHERS, REPRODUCED OR TRANSMITTED IN ANY FORM OR BY ANY MEANS, WITHOUT THE WRITTEN PERMISSION OF DANIELS MANUFACTURING CORP. ON COMPLETION OF ORDER OR OTHER PURPOSE FOR WHICH LENT.

DO NOT SCALE DRAWING

ITEM	PART NO.	QTY.	DESCRIPTION/REMARKS
DRN. A. MOO-YOUNG	DATE 3-17-00		DANIELS MANUFACTURING CORP. ORLANDO, FLORIDA CAGE 11851
CHK'D. RRR	DATE 3-17-00		
APP'D.	DATE		
APP'D.	DATE		

NOTE:		WHERE USED:	
THIS DRAWING IS AN OUTLINE DRAWING OF THE RESPECTIVE INDICATED ACTUAL DIMC PART NUMBER IS DRAWING THE -ENV- SUFFIX		SIZE B	SCALE NTS
		POSTING	CAD P/N GS208-ENV
			SHEET 1 OF 1
			REV. 1

ENVELOPE DRAWING
CIRCULAR CRIMP TOOL