

REVISIONS				
REV. SYM.	E.C.O. NUMBER	DESCRIPTION	BY DATE	APP'D DATE
1		ORIGINAL RELEASE	K. KOONS 12.11.17	

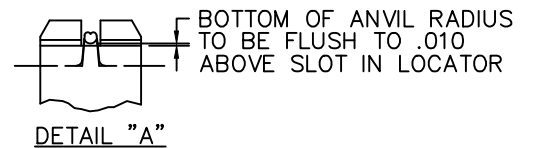

SEE
DETAIL "B"

SEE DETAIL "A"

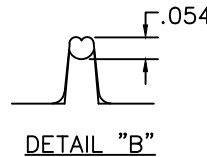
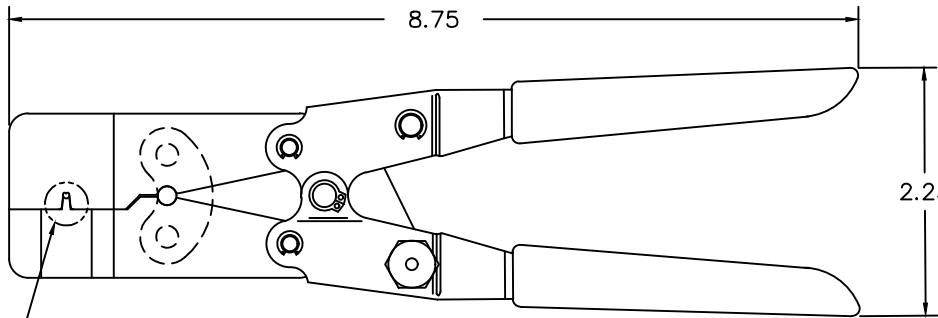
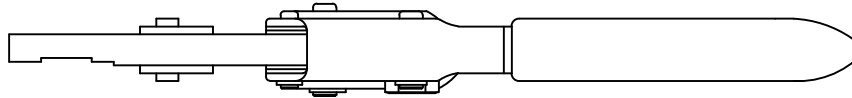
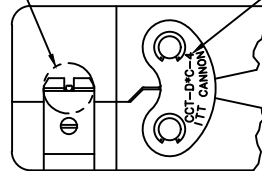
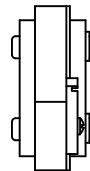

PERMANENTLY MARK ONE
LINK AS SHOWN
"CCT-D*C-4"
ITT CANNON

PERMANENTLY MARK ONE
LINK AS SHOWN

DMC
USA
GMT287

**UNCONTROLLED DOCUMENT
WILL NOT BE UPDATED**

DIMENSIONS IN INCHES - UNLESS OTHERWISE SPECIFIED

2. For Gaging (measure with a blade mic or vernier) sample crimp on .062 dia. 50/50 solid solder.

1. Hand tool ratchet release pressure 35 to 45 lbs.

NOTES:

RESTRICTED & CONFIDENTIAL		MATERIAL	ITEM	PART NO.	QTY.	DESCRIPTION/REMARKS	
CONFIDENTIAL PROPERTY OF DANIELS MANUFACTURING CORP. NOT TO BE DISCLOSED TO OTHERS, REPRODUCED OR USED FOR ANY OTHER PURPOSE, EXCEPT AS AUTHORIZED IN WRITING BY DANIELS MANUFACTURING. MUST BE RETURNED TO DANIELS MANUFACTURING CORP. ON COMPLETION OF ORDER OR OTHER PURPOSE FOR WHICH LENT.		HEAT TREAT	DRN.	K. KOONS	DATE	12.11.17	
			CHK'D.		DATE		
			APP'D.		DATE		
			APP'D.		DATE		
DO NOT SCALE DRAWING		FINISH	NOTE: THIS DRAWING IS AN OUTLINE DRAWING OF THE RESPECTIVE DMC PART NUMBER INDICATED. ACTUAL DMC PART NUMBER IS DRAWING NUMBER WITHOUT THE "-ENV" SUFFIX.			 DANIELS MANUFACTURING CORP. ORLANDO, FLORIDA CAGE 11851	
			TITLE				SHEET OF
			CRIMP TOOL ENVELOPE DRAWING				
			WHERE USED:				REV.
SIZE	SCALE	CAD P/N	GMT287-ENV				
B	NTS						
POSTING	P/N	GMT287			1		