

USERS MUST ENSURE CORRECT REVISION

REVISIONS				
REV. SYM.	E.C.O. NUMBER	DESCRIPTION	BY DATE	APP'D DATE
4		REVISED NOTES	ENF 6-30-14	RRR 6-30-14

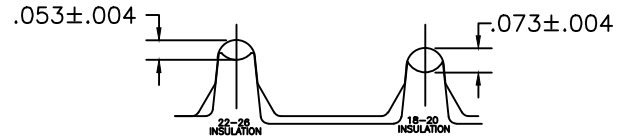

CRIMP FURTHEST FROM LOCATOR (USE .063" AND .093" SOFT COPPER TO CHECK)

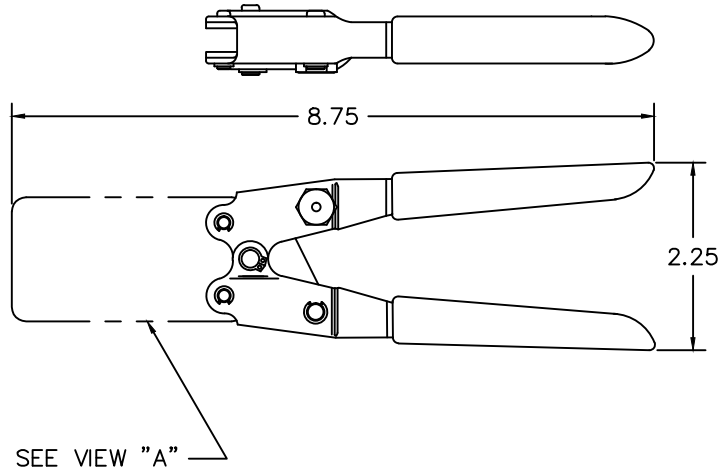
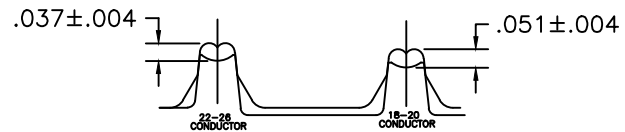

CRIMP CLOSEST TO LOCATOR (USE .063" SOFT COPPER TO CHECK)

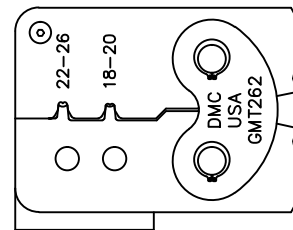
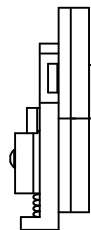
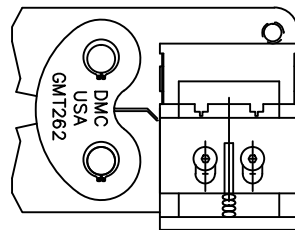

VIEW "A"

**UNCONTROLLED DOCUMENT
WILL NOT BE UPDATED**

⚠ CRIMP APPROPRIATE SIZE
DEAD SOFT COPPER WIRE AND MEASURE
WITH A BLADE MICROMETER.

NOTES:

RESTRICTED & CONFIDENTIAL CONFIDENTIAL PROPERTY OF DANIELS MANUFACTURING CORP. NOT TO BE DISCLOSED TO OTHERS, REPRODUCED OR USED FOR ANY OTHER PURPOSE, EXCEPT AS AUTHORIZED IN WRITING BY DANIELS MANUFACTURING. MUST BE RETURNED TO DANIELS MANUFACTURING CORP. ON COMPLETION OF ORDER OR OTHER PURPOSE FOR WHICH LENT.	MATERIAL	ITEM	PART NO.	QTY.	DESCRIPTION/REMARKS
	HEAT TREAT	DRN.	J. JOYCE	DATE 11/1/99	 DANIELS MANUFACTURING CORP. ORLANDO, FLORIDA CAGE 11851
		FINISH	CHK'D.	RRR	
	DO NOT SCALE DRAWING		APP'D.		DATE
		APP'D.		DATE	CRIMP TOOL ENVELOPE DRAWING
		NOTE: THIS DRAWING IS AN OUTLINE DRAWING OF THE RESPECTIVE DMC PART NUMBER INDICATED. ACTUAL DMC PART NUMBER IS DRAWING NUMBER WITHOUT THE "-ENV" SUFFIX.		WHERE USED:	
		SIZE	SCALE	CAD P/N	SHEET OF
		B	NTS	GMT262-ENV	1 1
		POSTING		DWG. NO. GMT262-ENV	REV. 4