

REVISIONS				
REV. SYM.	E.C.O. NUMBER	DESCRIPTION	BY DATE	APP'D DATE
2		UPDATED GAGE INFO	ENF 12/15	RRR 12/15

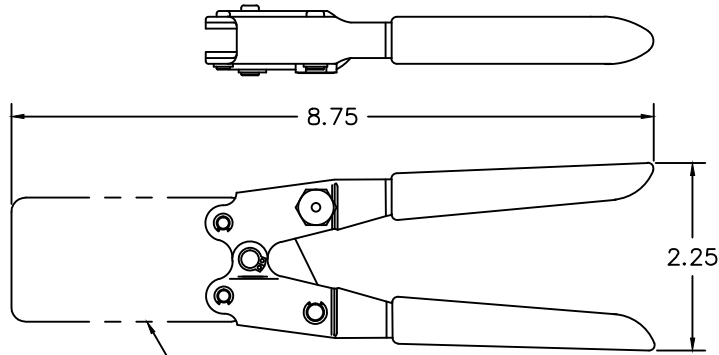

SEE VIEW "A"

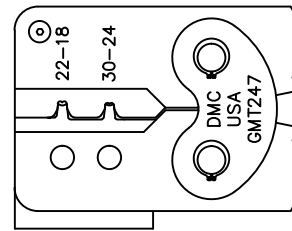
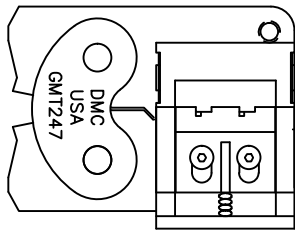
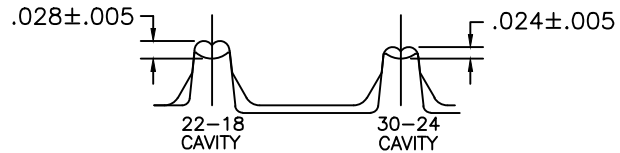

VIEW "A"

**UNCONTROLLED DOCUMENT
WILL NOT BE UPDATED**

2. FOR GAGE CHECK, CRIMP $\phi.062$
50/50 SOLID SOLDER AND MEASURE
WITH A BLADE MICROMETER.

1. ITT CANNON CCT-D*C-1.

NOTES:

RESTRICTED & CONFIDENTIAL CONFIDENTIAL PROPERTY OF DANIELS MANUFACTURING CORP. NOT TO BE DISCLOSED TO OTHERS, REPRODUCED OR USED FOR ANY OTHER PURPOSE, EXCEPT AS AUTHORIZED IN WRITING BY DANIELS MANUFACTURING. MUST BE RETURNED TO DANIELS MANUFACTURING CORP. ON COMPLETION OF ORDER OR OTHER PURPOSE FOR WHICH LENT.	MATERIAL	ITEM	PART NO.	QTY.	DESCRIPTION/REMARKS		
	HEAT TREAT	DRN. J. JOYCE	DATE 4/11/00		 DANIELS MANUFACTURING CORP. ORLANDO, FLORIDA GAGE 11851		
	FINISH	CHK'D. RRR	DATE 4/11/00				
	DO NOT SCALE DRAWING		APP'D.	DATE	TITLE	CRIMP TOOL ENVELOPE DRAWING	
		APP'D.	DATE	WHERE USED:			
		NOTE: THIS DRAWING IS AN OUTLINE DRAWING OF THE RESPECTIVE DMC PART NUMBER INDICATED. ACTUAL DMC PART NUMBER IS DRAWING NUMBER WITHOUT THE "-ENV" SUFFIX.		SIZE B	SCALE NTS	CAD P/N GMT247-ENV	SHEET OF 1 1
				POSTING	DWG. NO. GMT247-ENV	REV. 2	