

REVISIONS			
REV. NUMBER	DESCRIPTION	BY DATE	APPR'D DATE
1	ORIGINAL RELEASE	DMC 1/23/95	ME 1/95

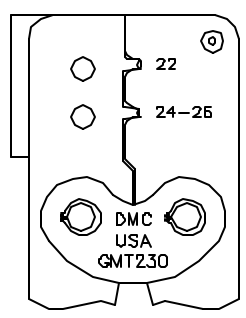
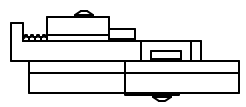
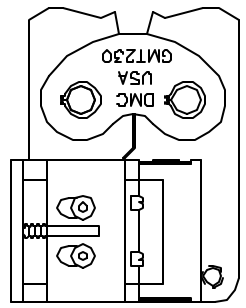
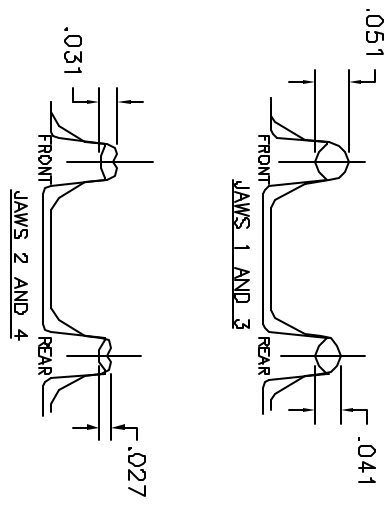
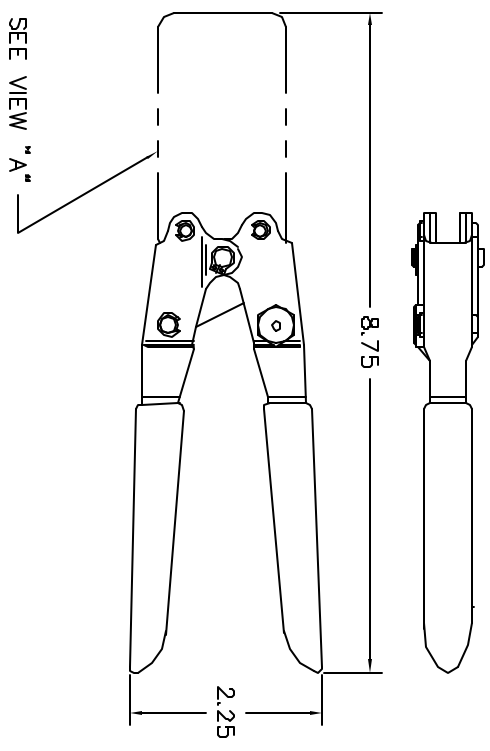

VIEW "A"

**UNCONTROLLED DOCUMENT  
WILL NOT BE UPDATED**

- FOR JAWS 1, 2, 3 & 4, CRIMP  $\phi$ .062 50/50 SOLID SOLDER AND MEASURE WITH A BLADE MICROMETER.

NOTES:

RESTRICTED & CONFIDENTIAL  
 PROPRIETARY PROPERTY OF DANIEL'S MANUFACTURING CORP. NOT TO BE DISCLOSED TO OTHERS, REPRODUCED OR USED FOR ANY OTHER PURPOSES WITHOUT THE WRITTEN PERMISSION OF DANIEL'S MANUFACTURING CORP. ON COMPLETION OF ORDER OR OTHER PURPOSE FOR WHICH INT.

MATERIAL		ITEM		PART NO.		QTY.		DESCRIPTION /REMARKS					
HEAT TREAT	FINISH	DMC	DVC	DATE	DATE								
		CHK'D.	DE	1/23/95	1/95								
		APPR'D.		DATE	DATE								
		APPR'D.		DATE	DATE								
DO NOT SCALE DRAWING		TITLE		WHERE USED		SIZE		SCALE		CAD P/N		SHEET OF	
		CRIMP TOOL ENVELOPE DRAWING		P/N		GMT230-ENV		1		1		1	
		DANIEL'S MANUFACTURING CORP. ORLANDO, FLORIDA (CASE 11851)		P/N		GMT230-ENV		1		1		1	