

USERS MUST ENSURE CORRECT REVISION

REVISIONS				
REV. SYM.	E.C.O. NUMBER	DESCRIPTION	BY DATE	APP'D DATE
1		ORIGINAL RELEASE	JWJ 1/14/00	RRR 1/14/00
2		NOTE 1 EQUIVALENT WAS 90302-1	TD 8-11-11	
3		REVISED FOR CLARITY	ENF 10-12-15	

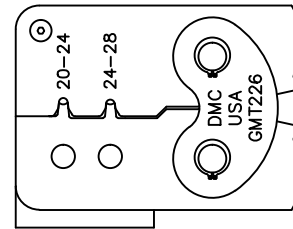
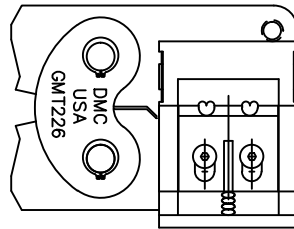
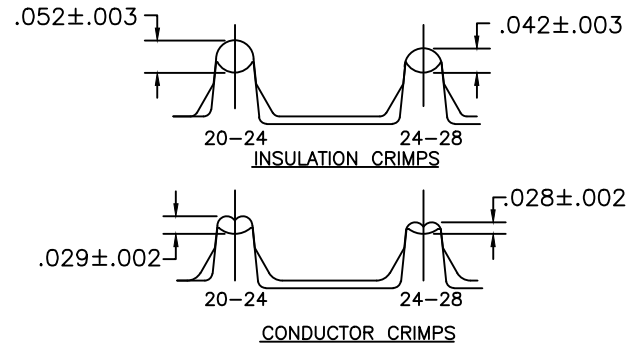
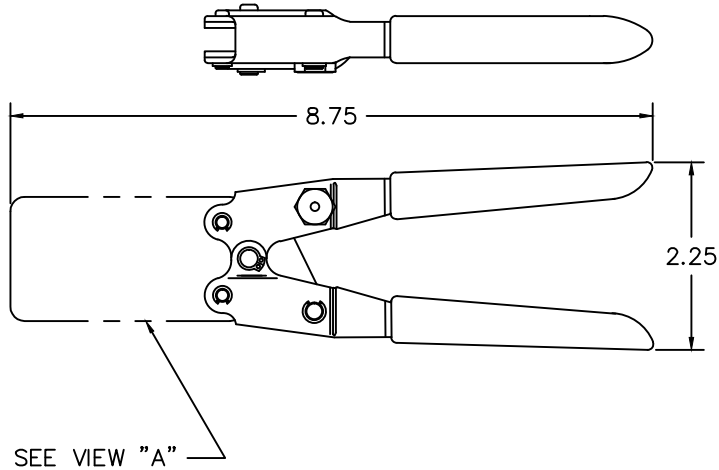

VIEW "A"

**UNCONTROLLED DOCUMENT
WILL NOT BE UPDATED**
DIMENSIONS IN INCHES - UNLESS OTHERWISE SPECIFIED

2. FOR GAGE VERIFICATION, CRIMP ϕ .062 50/50 SOLID SOLDER AND MEASURE WITH A BLADE MICROMETER.
1. AMP 91503-1 OR 58448-2 EQUIVALENT.

NOTES:

RESTRICTED & CONFIDENTIAL CONFIDENTIAL PROPERTY OF DANIELS MANUFACTURING CORP. NOT TO BE DISCLOSED TO OTHERS, REPRODUCED OR USED FOR ANY OTHER PURPOSE, EXCEPT AS AUTHORIZED IN WRITING BY DANIELS MANUFACTURING. MUST BE RETURNED TO DANIELS MANUFACTURING CORP. ON COMPLETION OF ORDER OR OTHER PURPOSE FOR WHICH LENT. DO NOT SCALE DRAWING	MATERIAL	ITEM	PART NO.	QTY.	DESCRIPTION/REMARKS			
	HEAT TREAT	DRN. J. JOYCE	DATE 1/14/00		 DANIELS MANUFACTURING CORP. ORLANDO, FLORIDA CAGE 11851			
	FINISH	CHK'D. RRR	DATE 1/14/00					
			APP'D.	DATE	TITLE	CRIMP TOOL ENVELOPE DRAWING		
		APP'D.	DATE	WHERE USED:				
		NOTE: THIS DRAWING IS AN OUTLINE DRAWING OF THE RESPECTIVE DMC PART NUMBER INDICATED. ACTUAL DMC PART NUMBER IS DRAWING NUMBER WITHOUT THE "-ENV" SUFFIX.		SIZE B	SCALE NTS	CAD P/N GMT226-ENV	SHEET 1	OF 1
				POSTING	DWG. NO. GMT226-ENV	REV. 3		