

REVISIONS				
REV. SYM.	E.C.O. NUMBER	DESCRIPTION	BY DATE	APP'D DATE
1		ORIGINAL RELEASE	K. KOONS 3.11.16	

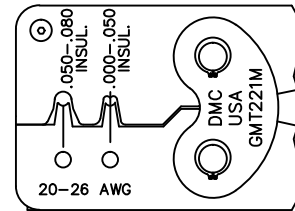
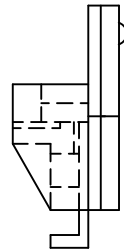
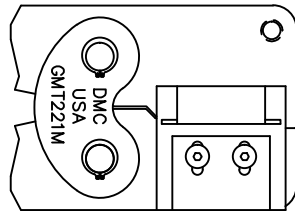
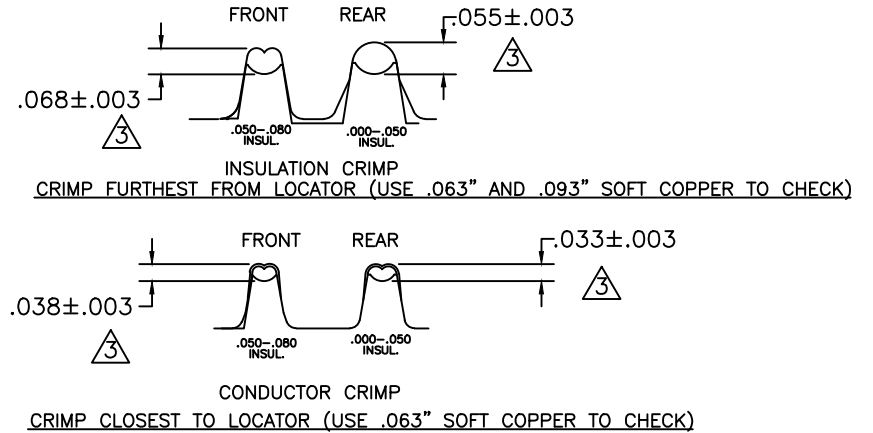
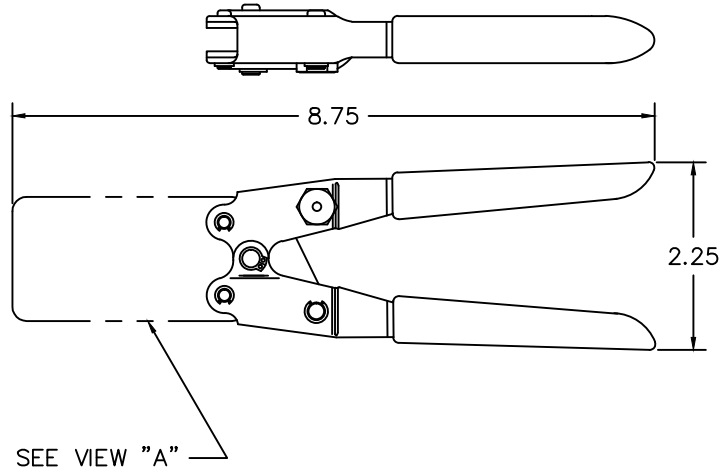

VIEW "A"

**UNCONTROLLED DOCUMENT
WILL NOT BE UPDATED**

DIMENSIONS IN INCHES - UNLESS OTHERWISE SPECIFIED

3. CRIMP ϕ .062 (FOR JAWS 2 & 4) AND ϕ .093 (FOR JAWS 1 & 3) 50/50 SOLID SOLDER AND MEASURE WITH A BLADE MICROMETER TO STATED TOLERANCES.
2. DELETED.
1. COLLINS EQUIVALENT.

NOTES:

<p>RESTRICTED & CONFIDENTIAL</p> <p>CONFIDENTIAL PROPERTY OF DANIELS MANUFACTURING CORP. NOT TO BE DISCLOSED TO OTHERS, REPRODUCED OR USED FOR ANY OTHER PURPOSE, EXCEPT AS AUTHORIZED IN WRITING BY DANIELS MANUFACTURING. MUST BE RETURNED TO DANIELS MANUFACTURING CORP. ON COMPLETION OF ORDER OR OTHER PURPOSE FOR WHICH LENT.</p>	MATERIAL	ITEM	PART NO.	QTY.	DESCRIPTION/REMARKS
	HEAT TREAT	DRN.	K. KOONS	DATE	 DANIELS MANUFACTURING CORP. ORLANDO, FLORIDA CAGE 11851
		CHK'D.		DATE	
	FINISH	APP'D.		DATE	TITLE
APP'D.			DATE	WHERE USED:	
DO NOT SCALE DRAWING	NOTE:		THIS DRAWING IS AN OUTLINE DRAWING OF THE RESPECTIVE DMC PART NUMBER INDICATED. ACTUAL DMC PART NUMBER IS DRAWING NUMBER WITHOUT THE "-ENV" SUFFIX.		
	SIZE	SCALE	CAD P/N	SHEET	OF
	B	NTS	GMT221M-ENV	1	1
	POSTING	DWG. NO.	REV.		
		GMT221M-ENV	1		