

REVISIONS				
REV. SYM.	E.C.O. NUMBER	DESCRIPTION	BY DATE	APP'D DATE
3		DELETED NOTE 2	JWJ 7/24/07	RRR 7/24/07
4		ADDED TOLERANCES	ENF 11-21-12	RRR 11-21-12

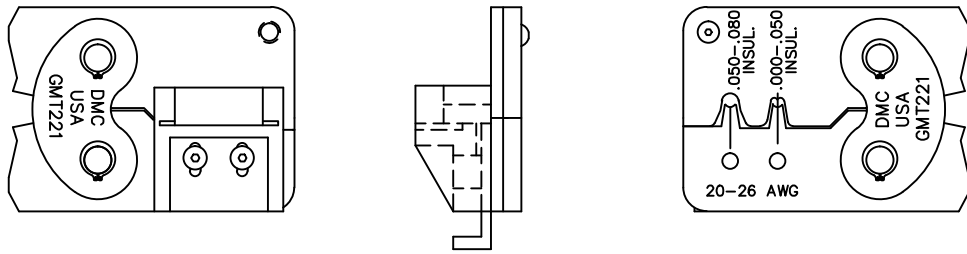
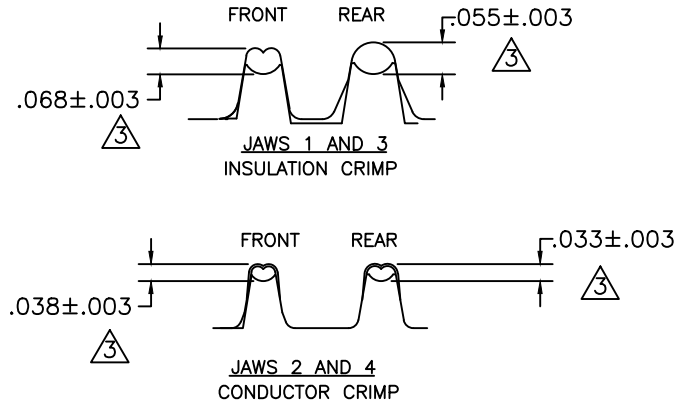
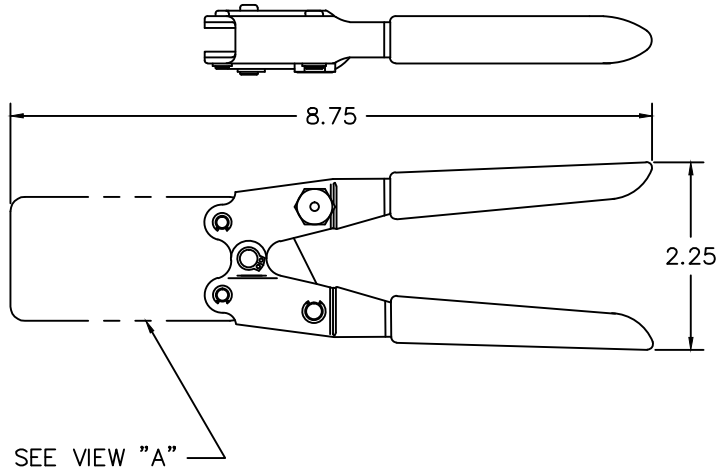

VIEW "A"

**UNCONTROLLED DOCUMENT
WILL NOT BE UPDATED**
DIMENSIONS IN INCHES - UNLESS OTHERWISE SPECIFIED

- 1. COLLINS EQUIVALENT.
- 2. DELETED.
- 3. CRIMP ϕ .062 (FOR JAWS 2 & 4) AND ϕ .093 (FOR JAWS 1 & 3) 50/50 SOLID SOLDER AND MEASURE WITH A BLADE MICROMETER TO STATED TOLERANCES.

NOTES:

RESTRICTED & CONFIDENTIAL CONFIDENTIAL PROPERTY OF DANIELS MANUFACTURING CORP. NOT TO BE DISCLOSED TO OTHERS, REPRODUCED OR USED FOR ANY OTHER PURPOSE, EXCEPT AS AUTHORIZED IN WRITING BY DANIELS MANUFACTURING. MUST BE RETURNED TO DANIELS MANUFACTURING CORP. ON COMPLETION OF ORDER OR OTHER PURPOSE FOR WHICH LENT.	MATERIAL	ITEM	PART NO.	QTY.	DESCRIPTION/REMARKS								
	HEAT TREAT	DRN. J. JOYCE	DATE 10/28/99		DANIELS MANUFACTURING CORP. ORLANDO, FLORIDA CAGE 11851								
	FINISH	CHK'D. RRR	DATE 10/28/99										
	DO NOT SCALE DRAWING		APP'D.	DATE	TITLE	CRIMP TOOL ENVELOPE DRAWING							
		NOTE: THIS DRAWING IS AN OUTLINE DRAWING OF THE RESPECTIVE DMC PART NUMBER INDICATED. ACTUAL DMC PART NUMBER IS DRAWING NUMBER WITHOUT THE "-ENV" SUFFIX.		WHERE USED:	<table border="1" style="font-size: small;"> <tr> <td>SIZE B</td> <td>SCALE NTS</td> <td>CAD P/N GMT221-ENV</td> <td>SHEET 1 OF 1</td> </tr> <tr> <td>POSTING</td> <td>DWG. NO. GMT221-ENV</td> <td>REV. 4</td> <td></td> </tr> </table>	SIZE B	SCALE NTS	CAD P/N GMT221-ENV	SHEET 1 OF 1	POSTING	DWG. NO. GMT221-ENV	REV. 4	
SIZE B	SCALE NTS	CAD P/N GMT221-ENV	SHEET 1 OF 1										
POSTING	DWG. NO. GMT221-ENV	REV. 4											