

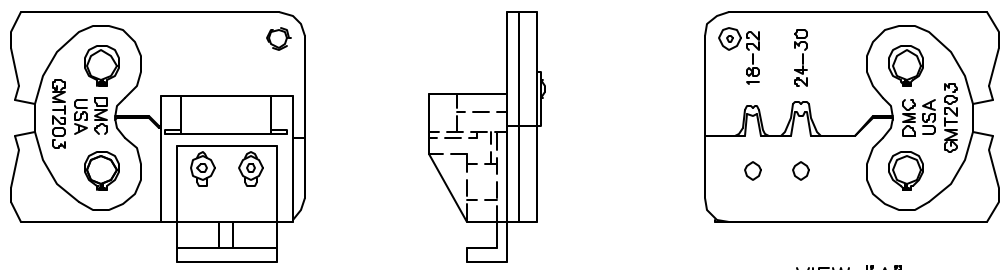

REVISIONS				
REV. SYM.	E.C.O. NUMBER	DESCRIPTION	BY DATE	APP'D DATE
1		ORIGINAL RELEASE	JS 1/28/88	DE 1/29

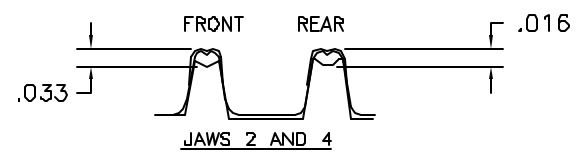
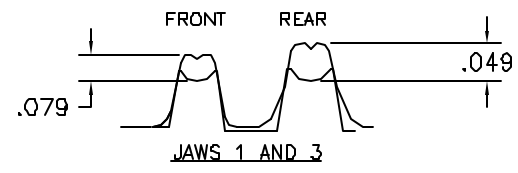
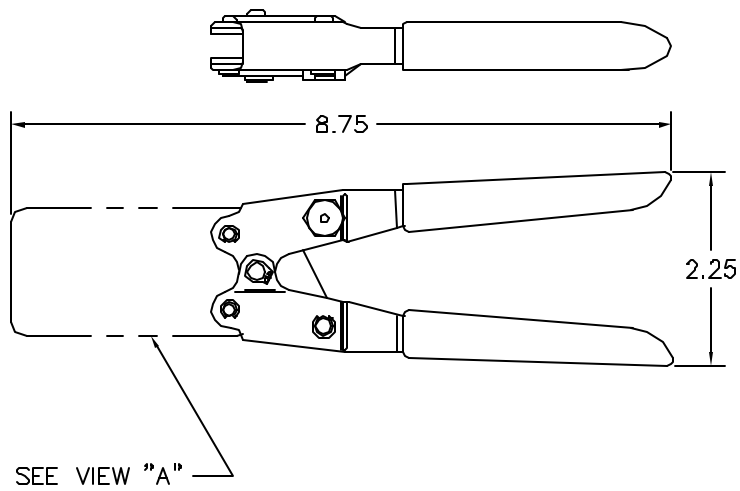

**UNCONTROLLED DOCUMENT
WILL NOT BE UPDATED**

1. FOR GAGING, MEASURE WITH A BLADE MICROMETER. SAMPLE CRIMP ON ϕ .062 50/50 SOLID SOLDER FOR INSULATION JAWS. SAMPLE CRIMP ON ϕ .093 50/50 SOLID SOLDER FOR CONDUCTOR JAWS.

NOTES:

RESTRICTED & CONFIDENTIAL CONFIDENTIAL PROPERTY OF DANIELS MANUFACTURING CORP. NOT TO BE DISCLOSED TO OTHERS, REPRODUCED OR USED FOR ANY OTHER PURPOSE, EXCEPT AS AUTHORIZED IN WRITING BY DANIELS MANUFACTURING. MUST BE RETURNED TO DANIELS MANUFACTURING CORP. ON COMPLETION OF ORDER OR OTHER PURPOSE FOR WHICH LENT.	MATERIAL	ITEM	PART NO.	QTY.	DESCRIPTION/REMARKS			
	HEAT TREAT	DRN	JS	DATE	 DANIELS MANUFACTURING CORP. ORLANDO, FLORIDA CAGE 11857			
		CHK'D.	MGS	DATE				
	FINISH	APP'D.	AAM	DATE		TITLE		
APP'D.			DATE	CRIMP TOOL ENVELOPE DRAWING				
DO NOT SCALE DRAWING				WHERE USED:				
				SIZE	SCALE	CAD P/N	SHEET	OF
				B	NTS	GMT203-ENV	1	1
				POSTING		P/N	REV.	
						GMT203-ENV	1	