

REVISIONS				
REV. STM.	E.C.O. NUMBER	DESCRIPTION	BY DATE	APP'D DATE
2		ADDED TOLERANCES	ENF 6/8/16	RRR 6/8/16

**UNCONTROLLED DOCUMENT
WILL NOT BE UPDATED**

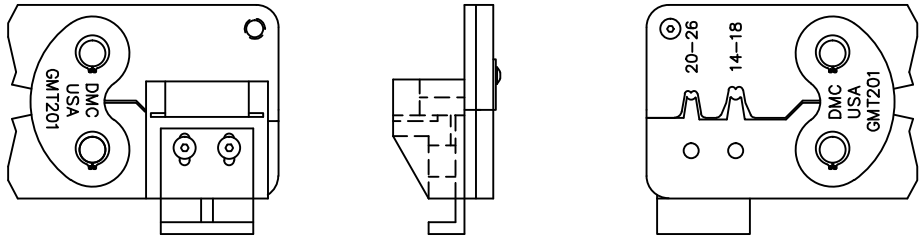
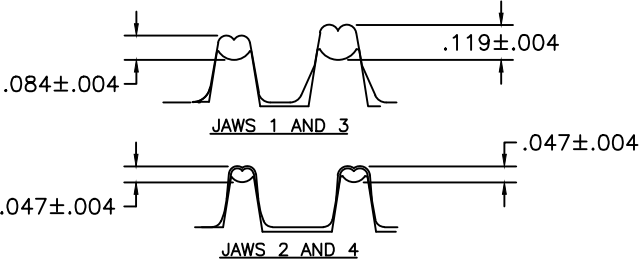
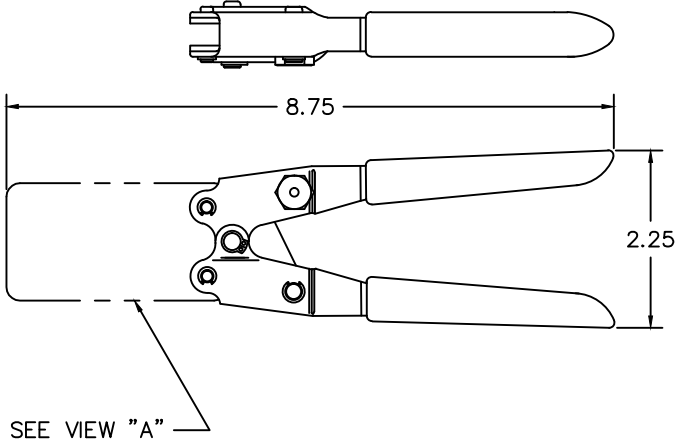

1. FOR JAWS 1, 2, 3 & 4, CRIMP APPROPRIATE SIZE 50/50 SOLID SOLDER AND MEASURE WITH A BLADE MICROMETER.

NOTES:

RESTRICTED & CONFIDENTIAL		MATERIAL		ITEM	PART NO.	QTY.	DESCRIPTION/REMARKS		
CONFIDENTIAL PROPERTY OF DANIELS MANUFACTURING CORP. NOT TO BE DISCLOSED TO OTHERS, REPRODUCED OR USED FOR ANY OTHER PURPOSE, EXCEPT AS AUTHORIZED IN WRITING BY DANIELS MANUFACTURING. MUST BE RETURNED TO DANIELS MANUFACTURING CORP. ON COMPLETION OF ORDER OR OTHER PURPOSE FOR WHICH LENT.		HEAT TREAT		DRN.	J. JOYCE	DATE	11/9/99		
				CHK'D.	RRR	DATE	11/9/99		
				APP'D.		DATE			
DO NOT SCALE DRAWING		FINISH		APP'D.		DATE			
				NOTE:				WHERE USED:	
				THIS DRAWING IS AN OUTLINE DRAWING OF THE RESPECTIVE DMC PART NUMBER INDICATED. ACTUAL DMC PART NUMBER IS DRAWING NUMBER WITHOUT THE "-ENV" SUFFIX.				SIZE	SCALE
				B	NTS	GMT201-ENV	1 1		
				POSTING		DMG. NO.	REV.		
						GMT201-ENV	2		