

Daniels Manufacturing Corporation offers complete refurbishing and recalibration services. DMC specially engineers and manufactures complete tool kits to satisfy individual customer requirements, such as total aircraft support, general shop maintenance or production, on board ship and vehicle service, etc.

#### LIMITATION OF LIABILITY

DANIELS MANUFACTURING CORPORATION IS NOT LIABLE FOR CONSEQUENTIAL OR SPECIAL DAMAGES OF ANY NATURE OR KIND RESULTING FROM THE USE, OR MISUSE, OF ANY OF ITS PRODUCTS. OWNERS AND USERS OF DMC PRODUCTS ASSUME FULL RESPONSIBILITY FOR INSTRUCTING THEIR EMPLOYEES IN THE PROPER AND SAFE USE OF SUCH PRODUCTS.

#### LIMITED WARRANTY

DMC (Daniels Manufacturing Corporation) warrants each new product sold by it to be free from defects in material and workmanship under normal use and service. DMC's obligation under this warranty is limited to the free correction or, at DMC's option, the refund of the purchase price of any such product which proves defective in normal service within ninety (90) days after delivery to the first user, provided that the product is returned to DMC with all transportation charges prepaid and which shall appear to DMC's satisfaction, after DMC's inspection, to have been defective in material or workmanship, it being understood that DMC products are not consumer products. This warranty shall not cover any damage to any product which, in the opinion of DMC, was caused by normal wear, misuse, improper operation, tampering, neglect or accident. This warranty is in lieu of all other warranties express or implied. No warranty, express or implied, is made or authorized to be made or assumed with respect to products of Daniels Manufacturing Corporation other than those herein set forth.

## 86-37 UNIVERSAL POSITIONER

## DATASHEET



SEE REVERSE SIDE FOR IMPORTANT INFORMATION CONCERNING LIMITED WARRANTY, AND LIMITATION OF LIABILITY.

The 86-37 Universal Positioner is used with the MH860 crimp tools to locate contacts horizontally and vertically between the indenters of the tools.

### INSTRUCTIONS

**CAUTION:** Before installing or removing the positioner from the crimp tool, be sure the adjustment screw is at least one complete turn outward from the inner limit of adjustment (turn the adjustment screw counterclockwise for at least one full rotation).

1. Align the bayonet pins of the positioner with the slots in the crimp tool. Insert and push positioner against the spring, then rotate the positioner 90° so that the bayonet pins fall into the internal slots of the tool. The positioner is now secured to the tool frame.
2. Raise and rotate the selector knob to the desired setting.
3. Screw the jam nut away from the positioner body and turn the adjustment screw clockwise to its highest setting.
4. Insert the contact to be crimped, into the locator. The contact should now be sitting too high into the tool. Turn the adjustment screw counterclockwise to move the contact lower into the crimp tool, until the indenters of the tool are estimated to be centered between the inspection hole and the top of the wire barrel. If the contact is designed with an insulation cup, adjust the vertical location of the contact so that the indenters are centered between the inspection hole and the bottom of the insulation cup.
5. When the ideal positioner adjustment is achieved for the contact, tighten the jam nut against the positioner body in order to lock the adjustment screw in place. The tool and positioner assembly is now ready for crimping the designated contact.

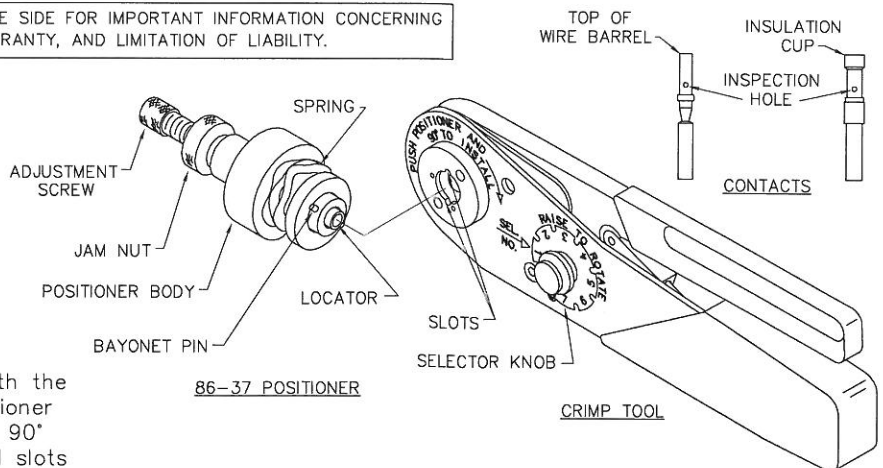

SEE REVERSE SIDE FOR IMPORTANT INFORMATION CONCERNING LIMITED WARRANTY, AND LIMITATION OF LIABILITY.

The 86-37 Universal Positioner is used with the MH860 crimp tools to locate contacts horizontally and vertically between the indenters of the tools.

#### INSTRUCTIONS

**CAUTION:** Before installing or removing the positioner from the crimp tool, be sure the adjustment screw is at least one complete turn outward from the inner limit of adjustment (turn the adjustment screw counterclockwise for at least one full rotation).

1. Align the bayonet pins of the positioner with the slots in the crimp tool. Insert and push positioner against the spring, then rotate the positioner 90° so that the bayonet pins fall into the internal slots of the tool. The positioner is now secured to the tool frame.
2. Raise and rotate the selector knob to the desired setting.
3. Screw the jam nut away from the positioner body and turn the adjustment screw clockwise to its highest setting.
4. Insert the contact to be crimped, into the locator. The contact should now be sitting too high into the tool. Turn the adjustment screw counterclockwise to move the contact lower into the crimp tool, until the indenters of the tool are estimated to be centered between the inspection hole and the top of the wire barrel. If the contact is designed with an insulation cup, adjust the vertical location of the contact so that the indenters are centered between the inspection hole and the bottom of the insulation cup.
5. When the ideal positioner adjustment is achieved for the contact, tighten the jam nut against the positioner body in order to lock the adjustment screw in place. The tool and positioner assembly is now ready for crimping the designated contact.

DANIELS MANUFACTURING CORP., 526 THORPE ROAD, ORLANDO, FL 32824, USA, PHONE 407/855-6161, FAX 407/855-6884  
 COPYRIGHT © 2002 DANIELS MANUFACTURING CORP., USA. WWW.DMCTOOLS.COM E-MAIL: DMC@DMCTOOLS.COM ALL RIGHTS RESERVED.

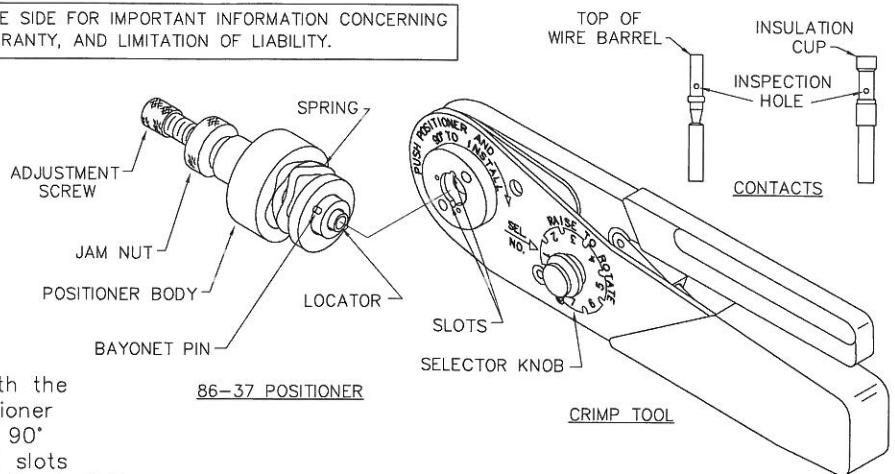

Daniels Manufacturing Corporation offers complete refurbishing and recalibration services.

DMC specially engineers and manufactures complete tool kits to satisfy individual customer requirements, such as total aircraft support, general shop maintenance or production, on board ship and vehicle service, etc.

#### LIMITATION OF LIABILITY

DANIELS MANUFACTURING CORPORATION IS NOT LIABLE FOR CONSEQUENTIAL OR SPECIAL DAMAGES OF ANY NATURE OR KIND RESULTING FROM THE USE, OR MISUSE, OF ANY OF ITS PRODUCTS. OWNERS AND USERS OF DMC PRODUCTS ASSUME FULL RESPONSIBILITY FOR INSTRUCTING THEIR EMPLOYEES IN THE PROPER AND SAFE USE OF SUCH PRODUCTS.

#### LIMITED WARRANTY

DMC (Daniels Manufacturing Corporation) warrants each new product sold by it to be free from defects in material and workmanship under normal use and service. DMC's obligation under this warranty is limited to the free correction or, at DMC's option, the refund of the purchase price of any such product which proves defective in normal service within ninety (90) days after delivery to the first user, provided that the product is returned to DMC with all transportation charges prepaid and which shall appear to DMC's satisfaction, after DMC's inspection, to have been defective in material or workmanship, it being understood that DMC products are not consumer products. This warranty shall not cover any damage to any product which, in the opinion of DMC, was caused by normal wear, misuse, improper operation, tampering, neglect or accident. This warranty is in lieu of all other warranties express or implied. No warranty, express or implied, is made or authorized to be made or assumed with respect to products of Daniels Manufacturing Corporation other than those herein set forth.