

USERS MUST ASSURE THEY ARE USING THE CORRECT REVISION.

**UNCONTROLLED DOCUMENT  
WILL NOT BE UPDATED**

**DIMENSIONS IN INCHES - UNLESS OTHERWISE SPECIFIED**

**REVISIONS**

REV	ECO NO.	DESCRIPTION	BY	DATE	APP'D BY	DATE
1		ORIGINAL RELEASE	K. KOONS	2/5/2015		
2		ADDED NOTE 1	K. KOONS	8/25/2015		
3		ADDED ISOMETRIC VIEW ; REVISED NOTE 1 ; ADDED PIN ORIENTATION NOTE	K. KOONS	9/14/2015		

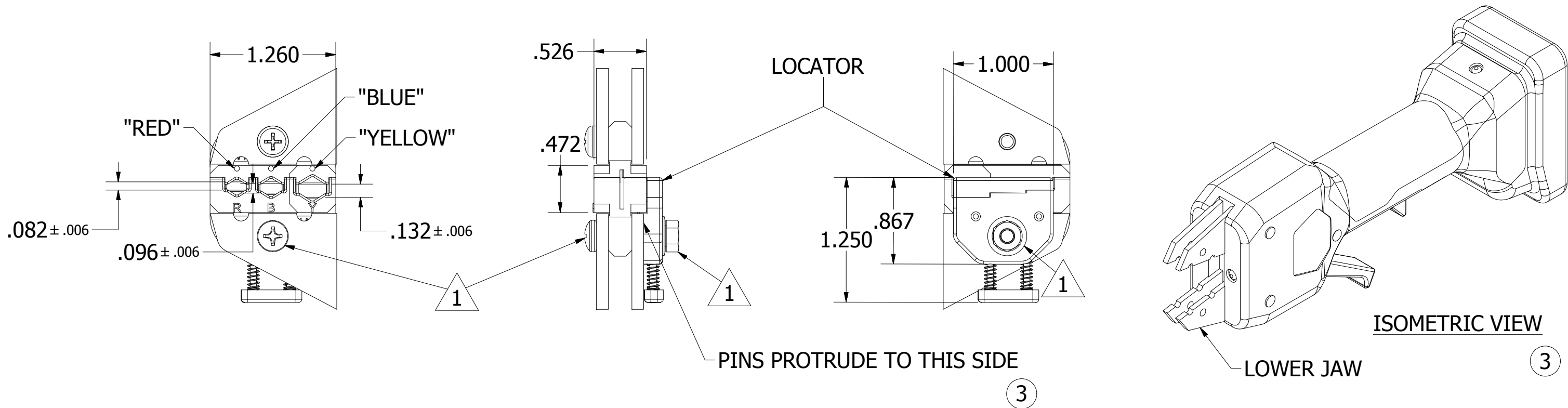

- 3. CHECK CRIMP HEIGHTS WITH G931.
- 2. FOR USE ON COMMERCIAL GRADE RED, BLUE & YELLOW INSULATED LUGS.

- ② ① REMOVE THE LOWER JAW EXISTING MACHINE SCREW, AND REPLACE WITH SUPPLIED M4 X 20mm SCREW. THEN INSTALL THE ASSEMBLED LOCATOR ONTO THE SCREW, WITH THE PINS TOWARD THE JAW, AND LOCK IT DOWN WITH THE SUPPLIED HEX LOCKNUT.
- ③

**NOTES:**

MATERIAL	ITEM	PART NO.	QTY.	DESCRIPTION / REMARKS
NA	DRN. KIRK C KOONS CHK'D. TLM	DATE 2/23/2015 DATE 6/26/2015		<b>DMC</b> DANIELS MANUFACTURING CORP. ORLANDO, FLORIDA CAGE 11851
RESTRICTED & CONFIDENTIAL CONFIDENTIAL PROPERTY OF DANIELS MANUFACTURING CORP. NOT TO BE DISCLOSED TO OTHERS. REPRODUCTION OR USED FOR ANY OTHER PURPOSE EXCEPT AS AUTHORIZED IN WRITING BY DANIELS MANUFACTURING. MUST BE RETURNED TO DANIELS MANUFACTURING CORP. ON COMPLETION OF ORDER OR PURPOSES FOR WHICH LENT.	HEAT TREAT	NOTE: THIS DRAWING IS AN OUTLINE DRAWING OF THE RESPECTIVE DMC PART NUMBER INDICATED. ACTUAL DMC PART NUMBER IS CAD PART NUMBER WITHOUT THE "-ENV" SUFFIX	TITLE DIE SET, RBY WITH LOCATOR ENVELOPE DRAWING WHERE USED: EMC3300	
CREATED FROM AN INVENTOR MODEL. CHANGES MUST BE REFLECTED IN THE 3D PART	FINISH	NA	SIZE B	SCALE 2 : 1 CAD P/N EMC-102DL-ENV SHEET 1 OF 1 DWG. NO. EMC-102DL REV. 3
DO NOT SCALE DRAWING				