

# DBS-CG7 VERIFICATION INSPECTION GAGE FOR DBS-2100 BANDING TOOL

SEE PAGE 8 FOR IMPORTANT INFORMATION CONCERNING LIMITED  
WARRANTY AND LIMITATION OF LIABILITY.

## INTRODUCTION

The Daniels DBS-CG7 (M81306/1C) Verification Inspection Gage is designed for verifying the pre-set tension of the DBS-2100 manual banding tool. Reference DBS-2100 datasheet for the proper operation of the banding tool. Consult DMC for further information.

### 1.0 Gage Components and Operation Instructions

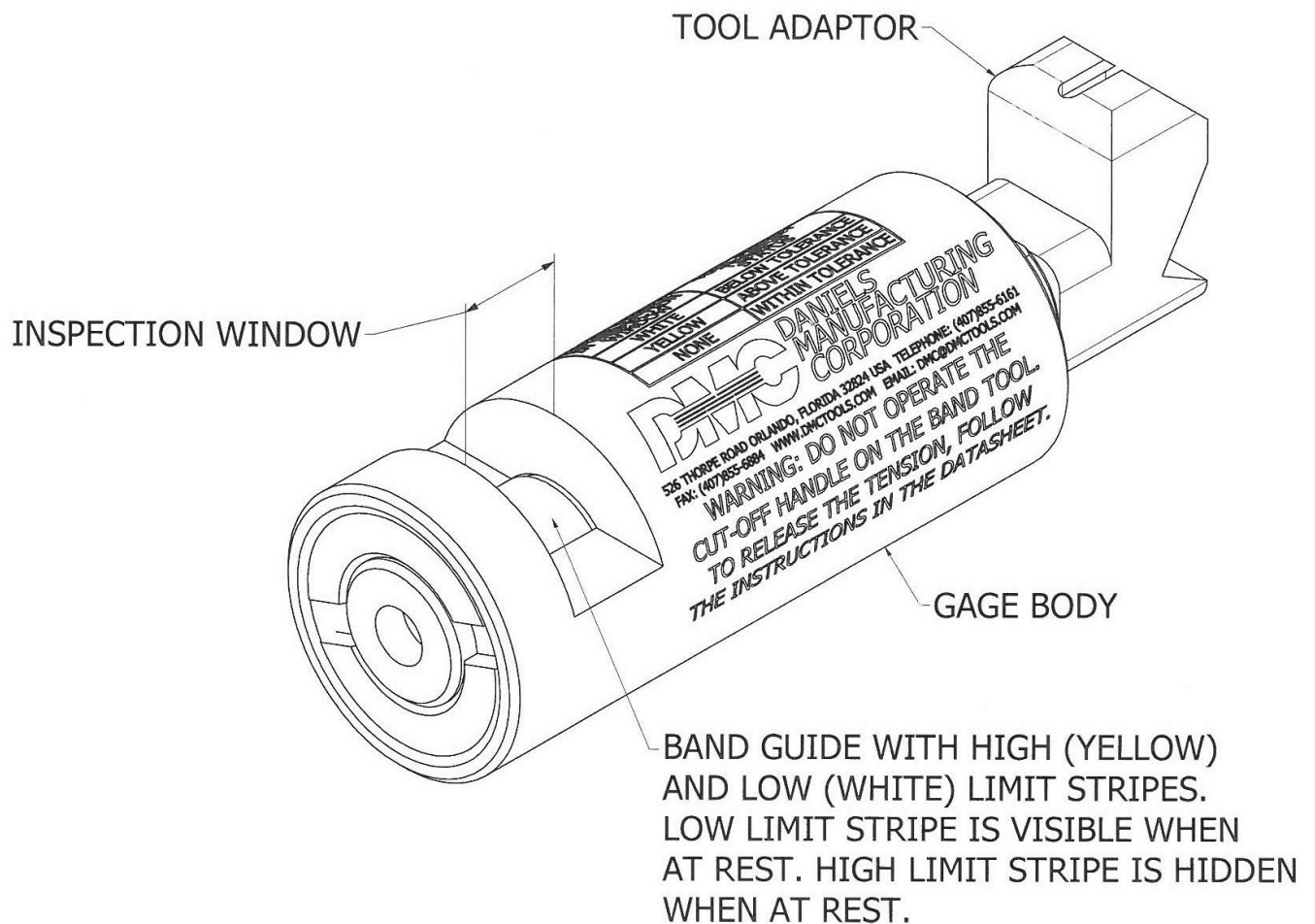

**Warning: Keep the DBS-CG7 in a clean, dry place when not in use. Keep the inspection window free from dust and debris.**

## 1.1 VERIFYING THE TENSION APPLIED TO THE BAND IS WITHIN 145-155 POUNDS.

### Step 1: Insert the band into the DBS-CG7

Insert the flat end of a ¼" wide band through the hole in the DBS-CG7. Pass the band through the DBS-CG7 until the buckle comes into contact with the end of the verification inspection gage.

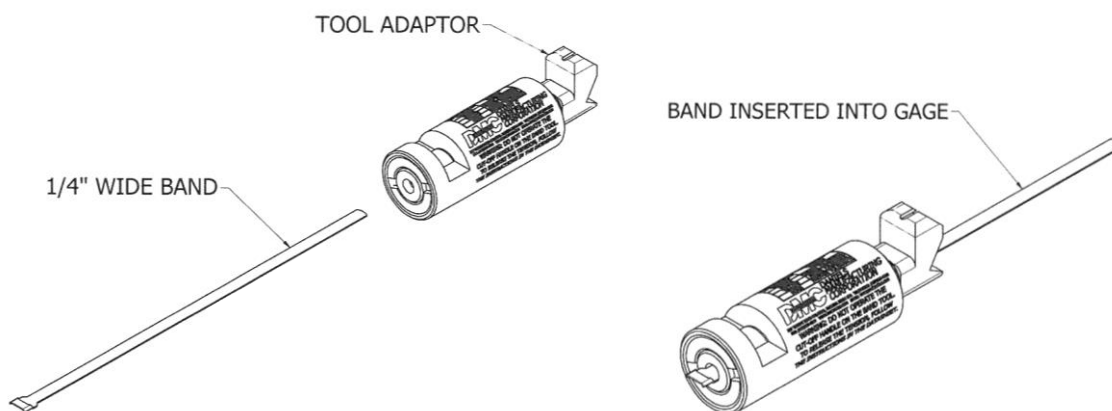

### Step 2: Insert the end of the band into the DBS-2100

Squeeze the grey release lever and insert the flat end of the band through the nose of the DBS-2100 far enough for the tool's advancement pawl to engage the band (approx. 1.5"). The band may be inserted further into the tool to hasten the process.

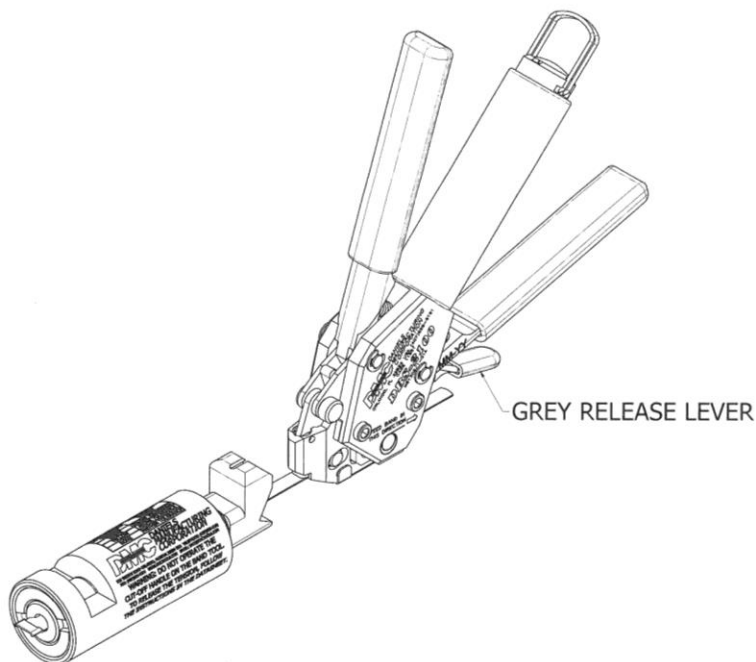

### Step 3: Align the tool with the verification inspection gage

Align the tool's nose so that it butts up against the DBS-CG7 as shown below.

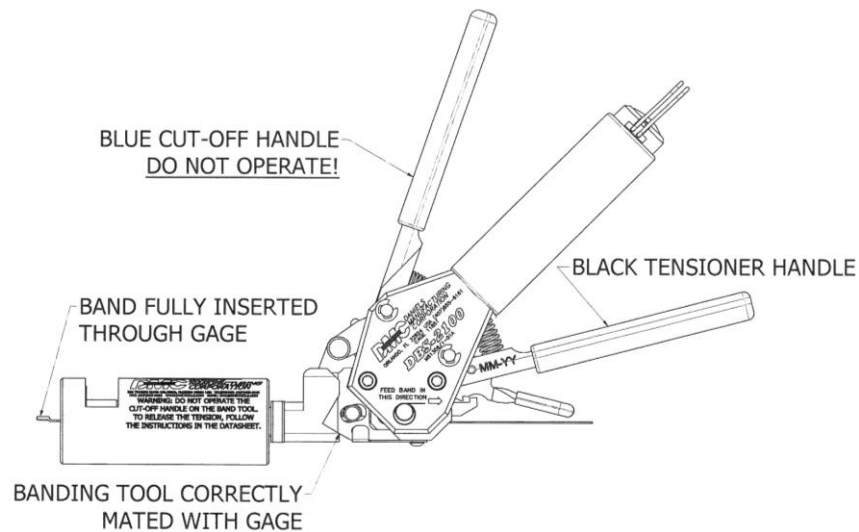

### Step 4: Lock the black tensioner handle

While ensuring the tool and verification inspection gage stay in the mated position (as shown above), repeatedly squeeze the black tensioner handle until the tool and DBS-CG7 are firmly docked. Slowly squeeze the black tensioner handle three times using partial strokes. Allow the tensioner handle to open fully and with one final stroke, squeeze the tensioner handle until it is retained in the closed position by the internal latching mechanism.

**Note: Rapid cycling of the tensioner handle may affect gaging.**

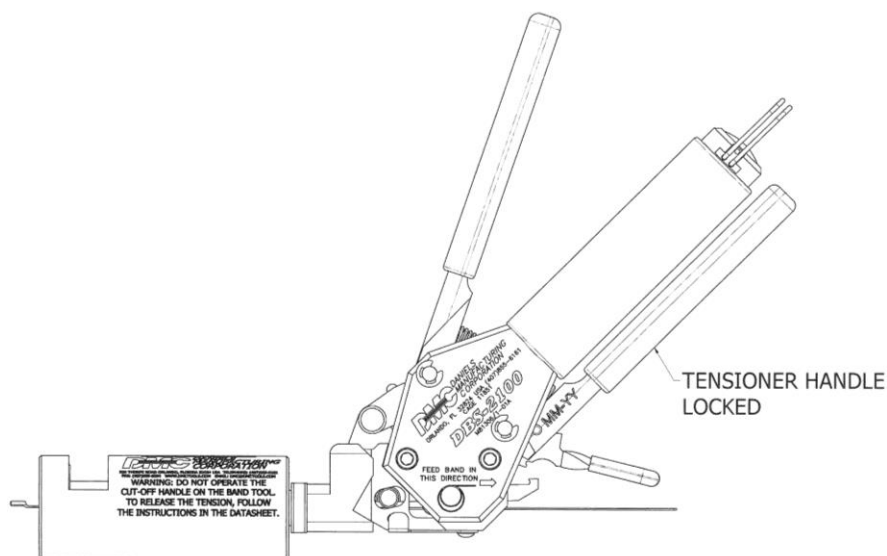

### Step 5: Look for Limit Stripes in Inspection window

With the black tensioner handle locked, look into the Inspection Window. If any amount of the white stripe is visible, the tension applied to the band by the DBS-2100 is below 145LBS. This indicates that the tension setting for the DBS-2100 must be adjusted. (See section 1.2 for adjustment instructions.)

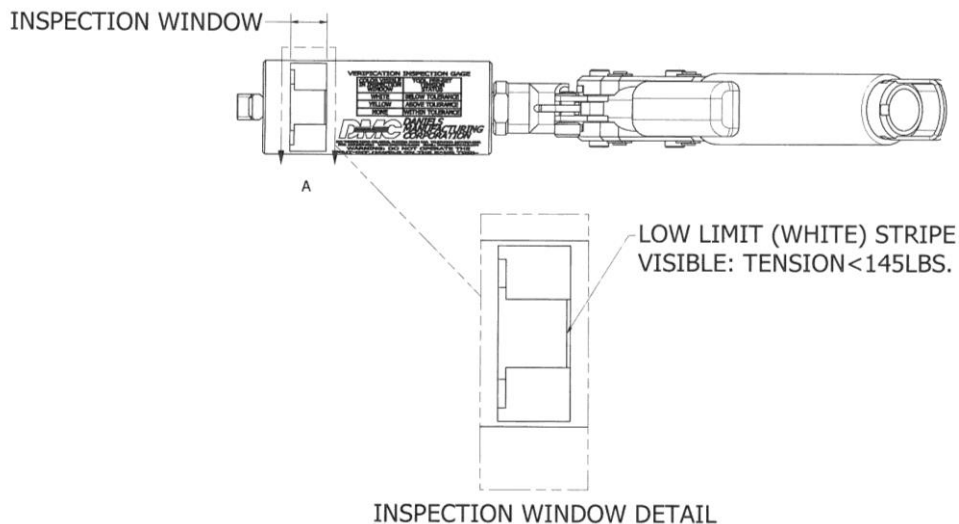

If no limit stripes are visible in the Inspection Window, the tension applied is between 145-155LBS. The Banding tool is within the acceptable range and does not require any adjustment.

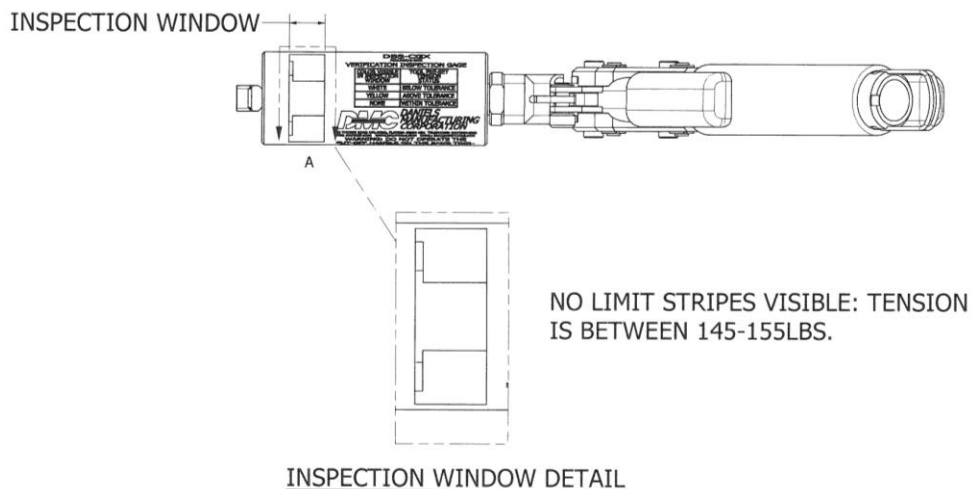

If any amount of the yellow stripe is visible, the tension applied to the band by the DBS-2100 is above 155LBS. This indicates that the tension setting for the DBS-2100 must be adjusted. (See section 1.2 for adjustment instructions.)

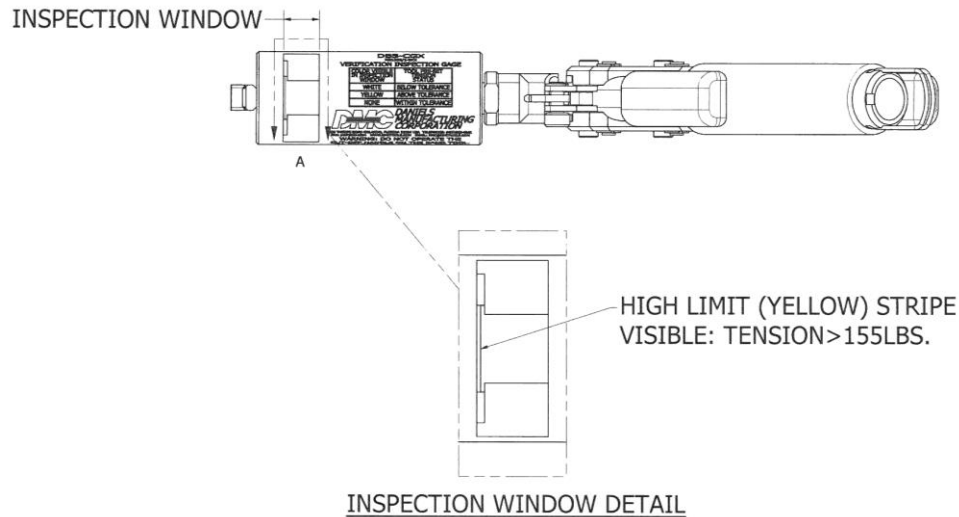

### Step 6: Remove the tension on the band

Squeeze the black tensioner handle and push the tension-lock lever forward. While holding the tension-lock lever forward, release the black tensioner handle. The tensioner handle will open fully. Squeeze the grey release lever and pull the band and DBS-CG7 away from the nose of the tool. (See DBS-2100 datasheet for more details on releasing the tension on the band.)

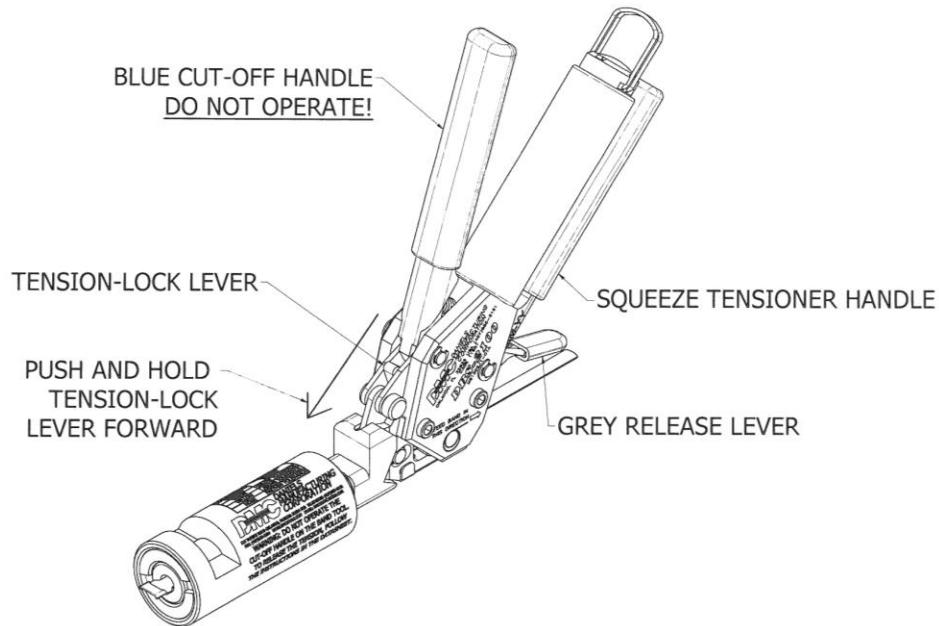

**NOTE: DO NOT ATTEMPT TO CUT THE BAND. DAMAGE TO THE TOOL AND/OR GAGE MAY OCCUR.**

## 1.2 ADJUSTING THE TENSION APPLIED BY THE TOOL

### Step 1: Remove the access plug

With a flat head screwdriver or similar tool, pry the plastic access plug out of the rear end of the tool.

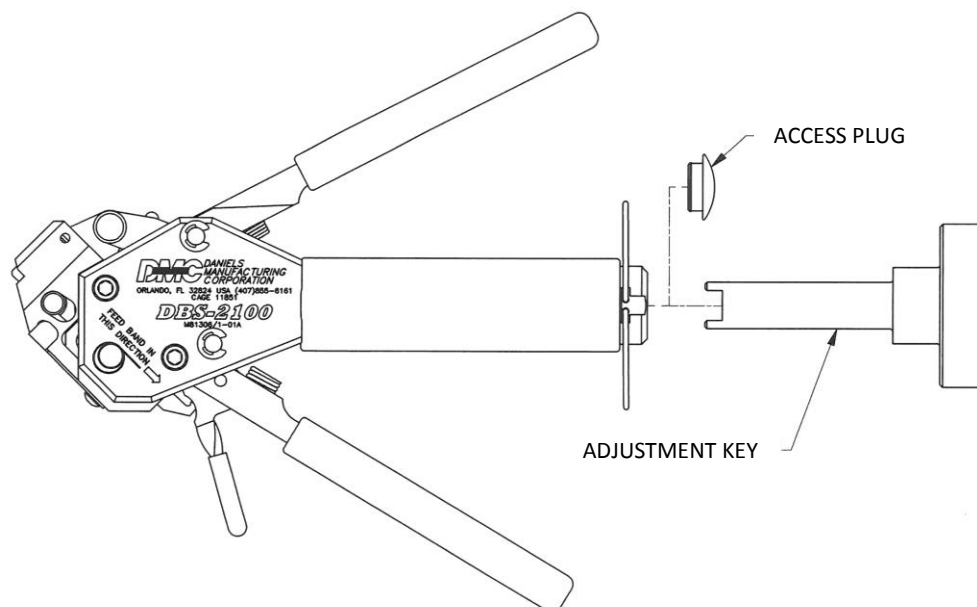

### Step 2: Insert the adjustment key into the access hole

Insert the adjustment key (p/n DBS-2100-32) through the access hole and engage the key with the adjustment nut inside the tool.

### Step 3: Adjust the spring preset

Turn the adjustment key either clockwise or counterclockwise in small increments ( $1/4$  to  $1/2$  turns) to change the tension that the tool will apply to the band during the termination process.

To INCREASE the tension, turn the adjustment key clockwise.

To DECREASE the tension, turn the key counterclockwise.

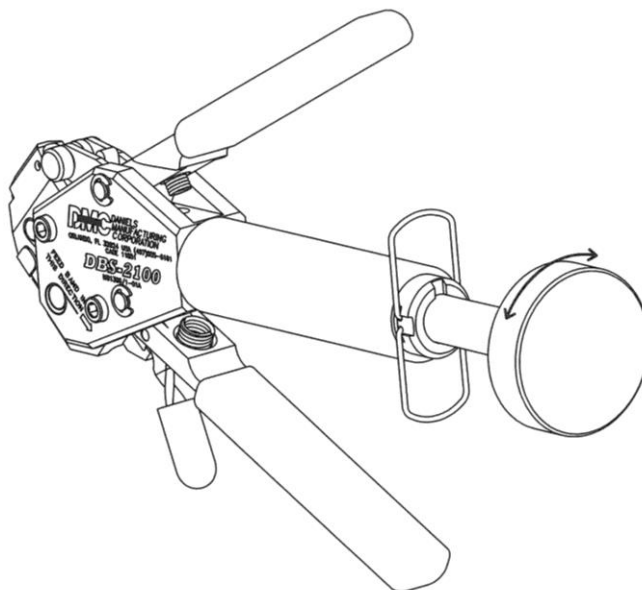

**Step 4: Verify the tension applied to the band is within the specified tolerance**

Follow Steps 1-5 in section 1.1 to verify that the tool is applying the appropriate tension to the band (145-155 pounds). If the tool requires further adjustment, follow steps 2-4 in this section. If the tool applies the appropriate tension, reinstall the access plug.

**CAUTION: Do not rotate any components of the DBS-CG7. To do so will alter the factory set calibration. Factory service and recalibration of the DBS-CG7 is available.**

Daniels Manufacturing Corporation offers complete refurbishing and recalibration services.

DMC specially engineers and manufactures complete tool kits to satisfy individual customer requirements, such as total aircraft support, general shop maintenance or production, on board ship and vehicle service, etc.

#### LIMITATION OF LIABILITY

Daniels Manufacturing Corporation is not liable for consequential or special damages of any nature or kind resulting from the use, or misuse, of any of its products. Owners and users of DMC products assume full responsibility for instructing their employees in the proper and safe use of such products.

#### LIMITED WARRANTY

DMC (Daniels Manufacturing Corporation) warrants each new product sold by it to be free from defects in material and workmanship under normal use and service. DMC's obligation under this warranty is limited to the free correction or, at DMC's option, the refund of the purchase price of any such product which proves defective in normal service within ninety (90) days after delivery to the first user, provided that the product is returned to DMC with transportation charges prepaid and which shall appear to DMC's satisfaction, it being understood that DMC products are not consumer products. This warranty shall not cover any damage to any product which, in the opinion of DMC, was caused by normal wear, misuse, improper operation, tampering, neglect or accident. This warranty is in lieu of all other warranties express or implied. No warranty, express or implied, is made or authorized to be made or assumed with respect to products of Daniels Manufacturing Corporation other than those herein set forth.