

REVISIONS

REV	ECO NO.	DESCRIPTION	BY	DATE	APP'D BY	DATE
A	25526	ORIGINAL RELEASE	CKB	9/9/2020	DPH	9/9/2020
B	28078	ADDED ADAPTORS TO COVER ALL KEYING PS.	KMG	1/17/2024	JJC	1/19/2024
C	30018	CHANGE FROM S3 CASE TO PELICAN	AV	1/21/2026	KMG	1/21/2026

RECEPTACLES

CONNECTOR PREFIX NUMBER	SHELL SIZE	KEYING POSITIONS	ADAPTER TOOL	T-HANDLE WRENCH	ADAPTER TOOL SET
AMPHENOL 2M805-003() 2M805-004()	8	A, B, F	CM805R-08A	BT-HT-100 (1/4" SQ. DRIVE)	CM-S-805R
	8	D, E	CM805R-08B		
	8	C	CM805R-08CC		
	9	A, B, F	CM805R-09A		
	9	D, E	CM805R-09B		
	9	C	CM805R-09CC		
	10	A, B, F	CM805R-10A		
	10	D, E	CM805R-10B		
	10	C	CM805R-10CC		
	11	A, B, F	CM805R-11A		
	11	D, E	CM805R-11B		
	11	C	CM805R-11CC		
GLENAIR 805-003() 805-004()	12	A, B, F	CM805R-12A		
	12	D, E	CM805R-12B		
	12	C	CM805R-12CC		

NOTES: 1/4" T-HANDLE IS PROVIDED FOR ADAPTER HOLDING, NOT APPLYING GREATER LEVERAGE.
ADAPTER TOOLS MADE TO FIT AMPHENOL 2M805 SERIES CONNECTORS.

RECEPTACLES

CONNECTOR PREFIX NUMBER	SHELL SIZE	KEYING POSITIONS	ADAPTER TOOL	T-HANDLE WRENCH	ADAPTER TOOL SET
AMPHENOL 2M805-003() 2M805-004()	15	A, B, F	CM805R-15A	BT-HT-100 (1/4" SQ. DRIVE)	CM-S-805R
	15	D, E	CM805R-15B		
	15	C	CM805R-15CC		
	18	A, B, F	CM805R-18A		
	18	D, E	CM805R-18B		
	18	C	CM805R-18CC		
	19	A, B, F	CM805R-19A		
	19	D, E	CM805R-19B		
	19	C	CM805R-19CC		
	23	A, B, F	CM805R-23A		
	23	D, E	CM805R-23B		
	23	C	CM805R-23CC		

NOTES: 1/4" T-HANDLE IS PROVIDED FOR ADAPTER HOLDING, NOT APPLYING GREATER LEVERAGE.
ADAPTER TOOLS MADE TO FIT AMPHENOL 2M805 SERIES CONNECTORS.

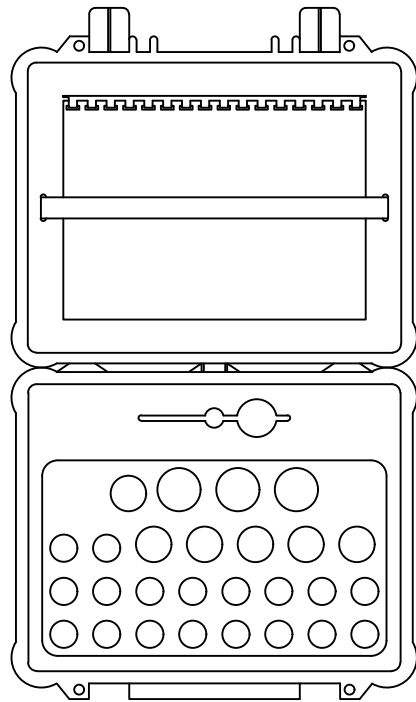

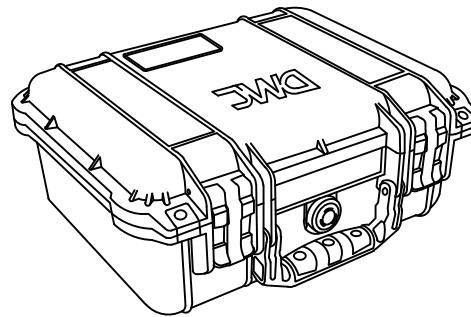

INTERIOR



ISOMETRIC VIEW

UNCONTROLLED DOCUMENT
WILL NOT BE UPDATED

MATERIAL	DRN	DATE	USERS MUST ASSURE THEY ARE USING THE CORRECT REVISION
N/A	CKB	9/9/2020	 DANIELS MANUFACTURING CORP. ORLANDO, FLORIDA CAGE 11851
	CHK'D	DATE	
	DPH	9/9/2020	
	APP'D	DATE	
	DPH	9/9/2020	
HEAT TREAT	N/A	TOLERANCE: UNLESS OTHERWISE SPECIFIED FRACTIONS = 1/32 ANGLE = 2° DECIMAL INCHES: .X = .020 .XX = .010 .XXX = .005 .XXXX = .0005 REMOVE BURRS AND BREAK SHARP EDGES .005 - .015 SURFACE FINISH TO BE  OR BETTER ALL OVER INTERNAL CORNER RADIUS .010 MAX	TITLE ADAPTER TOOL SET
FINISH	N/A		WHERE USED: SIZE SCALE A NTS
RESTRICTED & CONFIDENTIAL			CAD NO. CM-S-805R-ENV SHEET 1 OF 1 DWG. NO. CM-S-805R-ENV REV. C
CONFIDENTIAL PROPERTY OF DANIELS MANUFACTURING CORP. NOT TO BE DISCLOSED TO OTHERS. REPRODUCTION OR USED FOR ANY OTHER PURPOSE EXCEPT AS AUTHORIZED IN WRITING BY DANIELS MANUFACTURING. MUST BE RETURNED TO DANIELS MANUFACTURING CORP. ON COMPLETION OF ORDER OR PURPOSES FOR WHICH LENT.			
CREATED FROM AN AUTOCAD MODEL.			
DIMENSIONAL LIMITS APPLY AFTER FINISHING			
INTERPRET PER ASME Y14.5M-2018			