

REVISIONS

REV	ECO NO.	DESCRIPTION	BY	DATE	APP'D BY	DATE
1		INITIAL RELEASE	DPH	11/2/2020		
2		ADDED NOTES 1 & 2	CJY	4/17/2026	K. KOONS	4/17/2026

PART NUMBER	DIM "A"	DIM "B"	KEYING
CM803-05**	.30	.88	ALL
CM803-06**	.36	.88	ALL
CM803-07**	.44	.88	ALL
CM803-08**	.48	.88	ALL
CM803-09**	.51	.88	ALL
CM803-10**	.61	.88	ALL
CM803-12**	.71	1.00	ALL
CM803-14**	.86	1.00	ALL
CM803-15**	.91	1.00	ALL
CM803R-05**	.26	.88	ALL
CM803R-06**	.32	.88	ALL
CM803R-07**	.41	.88	ALL
CM803R-08**	.45	.88	ALL
CM803R-09**	.50	.88	ALL
CM803R-10**	.58	.88	ALL
CM803R-12**	.68	1.00	ALL
CM803R-14**	.83	1.00	ALL
CM803R-15**	.86	1.00	ALL

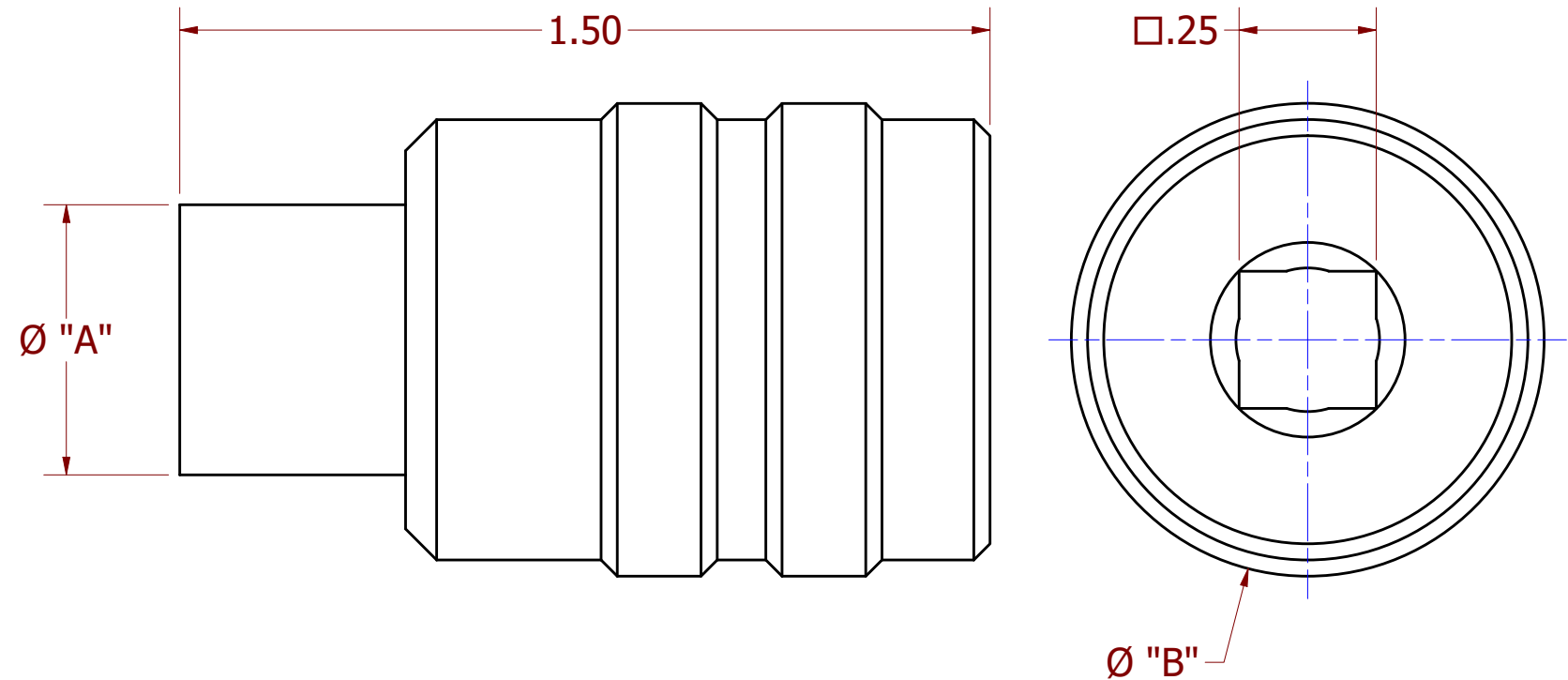

\*\* DENOTES PART NUMBER SUFFIX:

- AA = KEYING A
- BB = KEYING B
- CC = KEYING C
- DD = KEYING D
- EE = KEYING E
- FF = KEYING F

EXAMPLE PART NUMBER: CM803-08BB

1. ADAPTER TOOLS MADE TO FIT AMPHENOL 2M803 SERIES CONNECTORS.

\* INDICATES THAT ADAPTER TOOLS WILL ALSO FIT GLENAIR 803 "MIGHTY MOUSE SERIES CONNECTORS.

NOTES:

**UNCONTROLLED DOCUMENT  
WILL NOT BE UPDATED**

**DIMENSIONS IN INCHES - UNLESS OTHERWISE SPECIFIED**  
RESTRICTED & CONFIDENTIAL

CONFIDENTIAL PROPERTY OF DANIELS MANUFACTURING CORP. NOT TO BE DISCLOSED TO OTHERS. REPRODUCTION OR USED FOR ANY OTHER PURPOSE EXCEPT AS AUTHORIZED IN WRITING BY DANIELS MANUFACTURING. MUST BE RETURNED TO DANIELS MANUFACTURING CORP. ON COMPLETION OF ORDER OR PURPOSES FOR WHICH LENT.

DRN. DANIEL HENDESS	DATE 11/2/2020	INTERPRET PER ASME Y14.5M-2018	
CHK'D K. KOONS	DATE 11/2/2020	 <b>DANIELS MANUFACTURING CORP.</b> ORLANDO, FLORIDA CAGE 11851	
APP'D T. KUHL	DATE 4/17/2026		
NOTE: THIS DRAWING IS AN OUTLINE DRAWING OF THE RESPECTIVE DMC PART NUMBER INDICATED.		TITLE SERIES 2M803/803 ADAPTOR TOOLS ENVELOPE DRAWING	
WHERE USED:	SIZE	SCALE	CAD NO.
	B	N.T.S.	CM803_ENV
			PART NO.
			CM803
			SHEET
			1 OF 1
			REV.
			2