

REVISIONS				
REV. SYM.	E.C.O. NUMBER	DESCRIPTION	BY DATE	APP'D DATE
1		ORIGINAL RELEASE	K. KOONS 3.7.11	

T:\Pneu-Hyd-ELEC\HPU15M.jpg

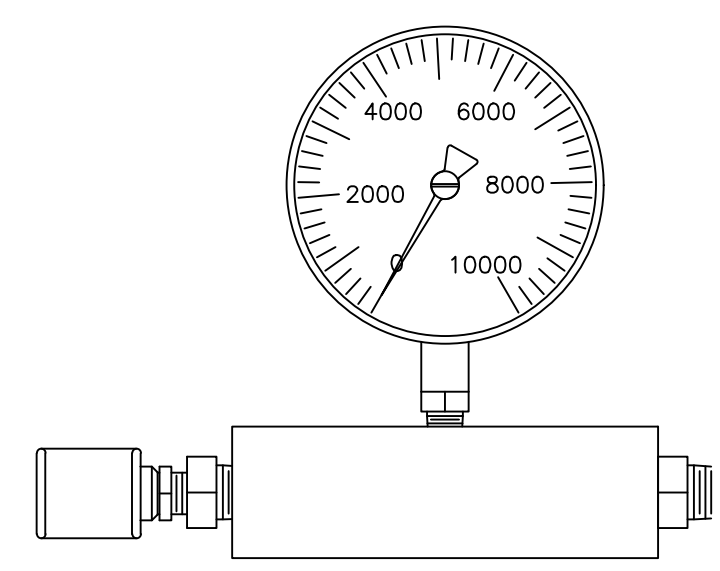

**UNCONTROLLED DOCUMENT
WILL NOT BE UPDATED**

DIMENSIONS IN INCHES - UNLESS OTHERWISE SPECIFIED

1. USABLE OIL CAPACITY = 38in^3
 PRESSURE RATING = 200 psi 1st STAGE / 10000 psi 2nd STAGE
 OIL DISPLACEMENT PER STROKE = $.687\text{in}^3$ 1st STAGE / $.151\text{in}^3$ 2nd STAGE
 MAX PEDAL EFFORT = 125lb
 WEIGHT = 16lb
 INTERNAL PISTON STROKE = 1.0in

NOTES:

RESTRICTED & CONFIDENTIAL		MATERIAL	ITEM	PART NO.	QTY.	DESCRIPTION/REMARKS
CONFIDENTIAL PROPERTY OF DANIELS MANUFACTURING CORP. NOT TO BE DISCLOSED TO OTHERS, REPRODUCED OR USED FOR ANY OTHER PURPOSE, EXCEPT AS AUTHORIZED IN WRITING BY DANIELS MANUFACTURING. MUST BE RETURNED TO DANIELS MANUFACTURING CORP. ON COMPLETION OF ORDER OR OTHER PURPOSE FOR WHICH LENT.		HEAT TREAT	DRN. K. KOONS	DATE 3.7.11	 DANIELS MANUFACTURING CORP. ORLANDO, FLORIDA CAGE 11851	TITLE
			CHK'D.	DATE		HYDRAULIC POWER UNIT, FOOT
			APP'D.	DATE		WHERE USED:
			APP'D.	DATE		SIZE B SCALE NTS DWG. NO. HPU15M-ENV SHEET 1 OF 1 POSTING P/N HPU15M-ENV REV. 1
DO NOT SCALE DRAWING		FINISH	NOTE: THIS DRAWING IS AN OUTLINE DRAWING OF THE RESPECTIVE DMC PART NUMBER INDICATED. ACTUAL DMC PART NUMBER IS DRAWING NUMBER WITHOUT THE "-ENV" SUFFIX.			