

DIE CLOSURES		
SEL NO	Ø GO	Ø NO-GO
5	.069	.074
6	.076	.081
7	.086	.095
8	.100	.110

**NOTES:**

- DIMENSIONS:  
 CRIMP TOOL: Ø 3.00 X 15.00  
 CRIMP AREA: Ø .325 MAX  
 BENCH MOUNT: 4.00 X 4.00 X 8.00  
 FOOT PEDAL: 8 X 6 X 5.8  
 HOSE: 9 FEET LONG
- MAY BE GAGED WITH G1005 ON SELECTOR SETTING 5

REVISIONS				
REV. SYM.	E.C.O. NUMBER	DESCRIPTION	BY DATE	APP'D DATE
1		ORIGINAL RELEASE	D.A.D. 11-10-97	DE 11-97
2		REVISED NOTE 2	JWJ 5-3-99	RRR 5-3-99
3		REVISED GAGE DIM'S	K. KOONS 5-9-00	RRR 5-9-00
4		REVISED PICTORIALY	K. KOONS 11-8-00	RRR 11-8-00
5		REPLACED WA10 WITH WA10A, AND REVISED PICTORIALY.	SAL 6-13-05	RRR 6-13-05
6		REVISED NOTE 2	L.MONTMINY 12-16-24	

**UNCONTROLLED DOCUMENT  
WILL NOT BE UPDATED**

**DIMENSIONS IN INCHES - UNLESS OTHERWISE SPECIFIED**

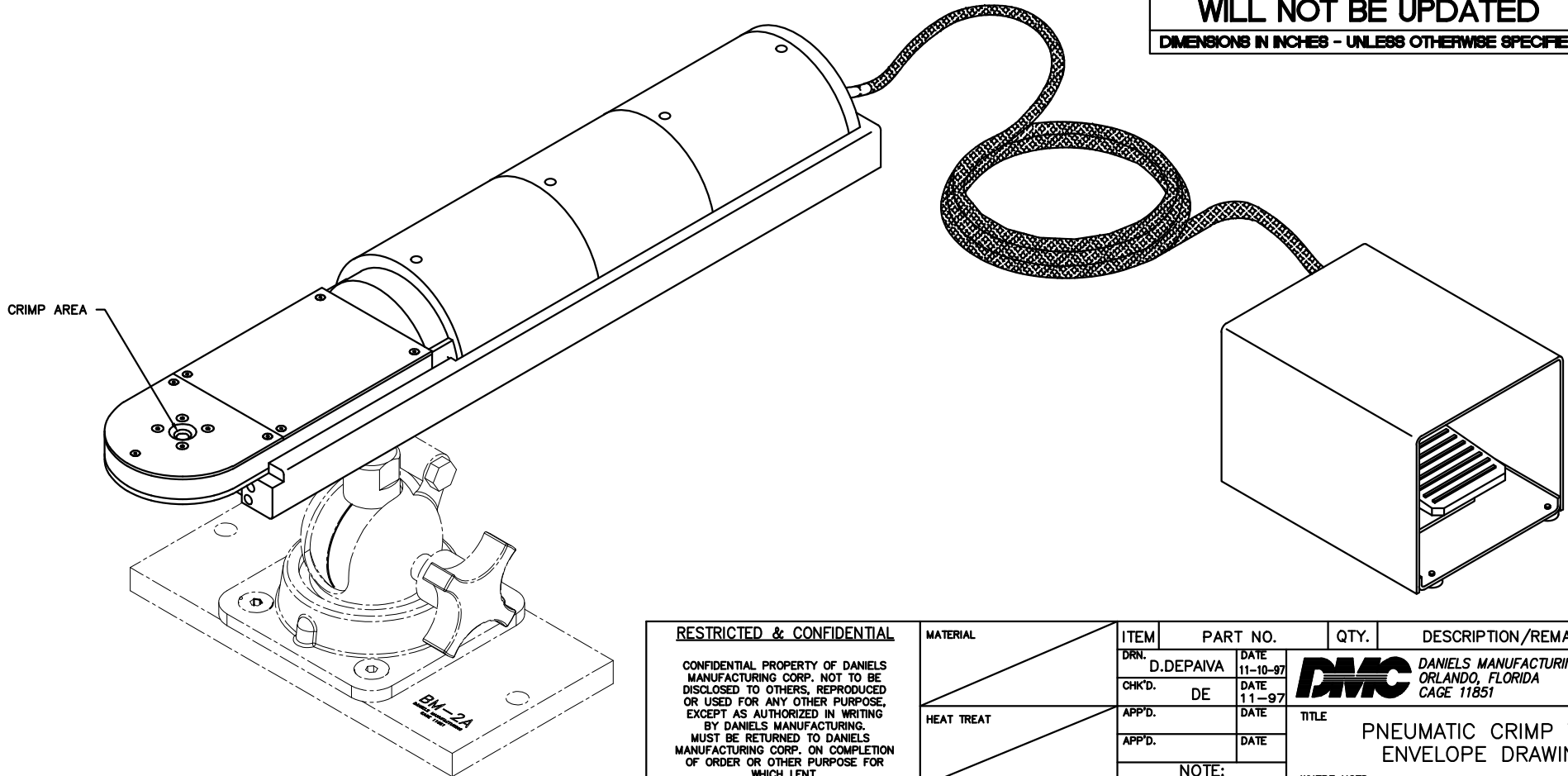

RESTRICTED & CONFIDENTIAL		MATERIAL	ITEM	PART NO.	QTY.	DESCRIPTION/REMARKS				
CONFIDENTIAL PROPERTY OF DANIELS MANUFACTURING CORP. NOT TO BE DISCLOSED TO OTHERS, REPRODUCED OR USED FOR ANY OTHER PURPOSE, EXCEPT AS AUTHORIZED IN WRITING BY DANIELS MANUFACTURING. MUST BE RETURNED TO DANIELS MANUFACTURING CORP. ON COMPLETION OF ORDER OR OTHER PURPOSE FOR WHICH LENT.		HEAT TREAT	DRN.	D.DEPAVA	DATE	<b>DMC</b> DANIELS MANUFACTURING CORP. ORLANDO, FLORIDA GAGE 11851				
			CHK'D.	DE	DATE					
			APP'D.		DATE	TITLE	PNEUMATIC CRIMP TOOL ENVELOPE DRAWING			
DO NOT SCALE DRAWING		FINISH	APP'D.		DATE	WHERE USED:				
			APP'D.		DATE	SIZE	SCALE	CAD P/N	SHEET	OF
			NOTE: THIS DRAWING IS AN OUTLINE DRAWING OF THE RESPECTIVE DMC PART NUMBER INDICATED. ACTUAL DMC PART NUMBER IS DRAWING NUMBER WITHOUT THE "-ENV" SUFFIX.		B	NTS	WA27-309-EP-ENV	1	1	
			POSTING	DWG. NO.	REV.					
				WA27-309-EP-ENV	6					