

REVISIONS				
REV. SYM.	E.C.O. NUMBER	DESCRIPTION	BY DATE	APP'D DATE
B	13077	UPDATED STAMP INFORMATION REDRAWN AND REVISED	DVC 12/8/94	DE 12/9/94

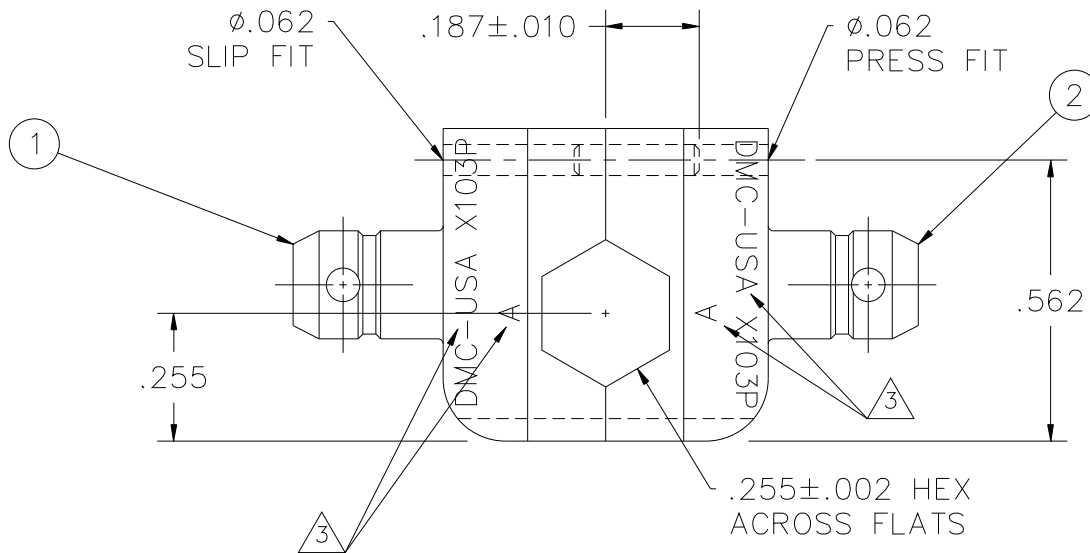

5	6-1032	1	Ø1/16 X 1/2 SPRING PIN
4	6-1024	1	Ø1/16 X 3/8 SPRING PIN
3	6-1190	1	Ø1/16 X 1/4 DOWEL PIN
2	HX3-4	1	MOVABLE DIE BLANK
1	HX3-6	1	STATIONARY DIE BLANK

4. ITEMS 4 AND 5 NOT SHOWN BUT SHIPPED WITH DIE SET.

3. PERMANENTLY MARK AS SHOWN, 3/64 HIGH CHARACTERS.

2. OPPOSING CAVITIES MUST ALIGN WITHIN .002.

1. CRIMPING SURFACES TO BE 63/

NOTES:

RESTRICTED & CONFIDENTIAL		MATERIAL		ITEM		PART NO.		QTY.		DESCRIPTION/REMARKS			
CONFIDENTIAL PROPERTY OF DANIELS MANUFACTURING CORP. NOT TO BE DISCLOSED TO OTHERS, REPRODUCED OR USED FOR ANY OTHER PURPOSE, EXCEPT AS AUTHORIZED IN WRITING BY DANIELS MANUFACTURING. MUST BE RETURNED TO DANIELS MANUFACTURING CORP. ON COMPLETION OF ORDER OR OTHER PURPOSE FOR WHICH LENT.		(OHTS-06)		DRN.	DVC	DATE	12/8/94	 DANIELS MANUFACTURING CORP. ORLANDO, FLORIDA CAGE 11851					
		HEAT TREAT		CHK'D.	DE	DATE	12/94						
		DO NOT SCALE DRAWING		FINISH		APP'D.	DD	DATE	12/94	TITLE			
				BLACK OXIDE MIL-C-13924		TOLERANCE: UNLESS OTHERWISE SPECIFIED FRACTIONS±1/32 ANGLES±1/2° DECIMAL INCHES: .X: ±.020 .XX: ±.010 .XXX: ±.005 .XXXX: ±.0005 REMOVE BURRS & BREAK SHARP EDGES .005-.015		WHERE USED:		SIZE	SCALE	CAD P/N	SHEET
				POSTING		P/N		X103P		1			
								X103P		REV. B			