

REVISIONS				
REV. SYM.	E.C.O. NUMBER	DESCRIPTION	BY DATE	APP'D DATE
A	13801	ORIGINAL RELEASE	D.A.D. 6-16-94	DE 6-27-94
B	18914	DELETE ITEM 1 AND 2 ADDED HX4-1064BK, ITEM 3 WAS	JMC 6-12-03	JWJ 6-12-03

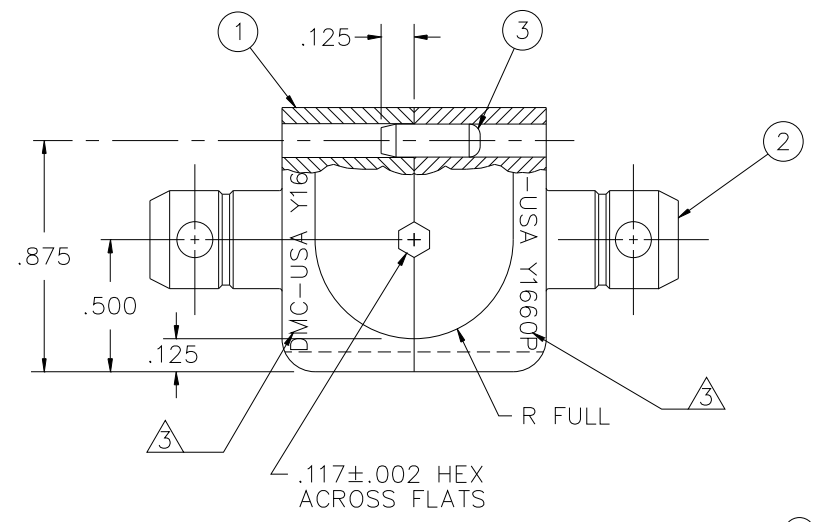
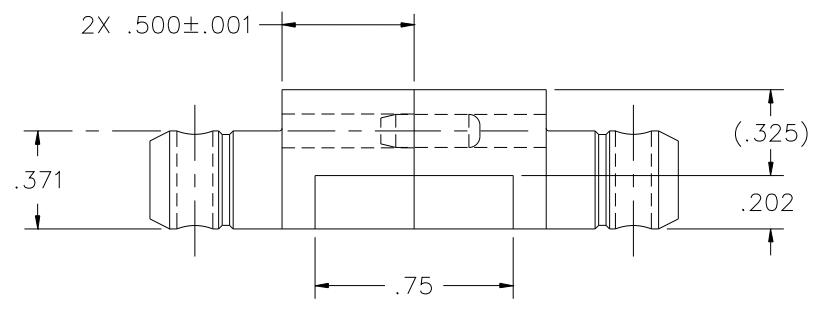

6. PRESS ITEM 3 INTO ITEM 2 TO DIMENSION SHOWN.
 5. PROJECT 3256: AG-1 EQUIVALENT.
 4. ITEMS 4 AND 5 NOT SHOWN BUT SHIPPED WITH DIE SET.
 - ⚠ PERMANENTLY MARK AS SHOWN, 1/16 HIGH CHARACTERS.
 2. OPPOSING CRIMPING CAVITES MUST ALIGN WITHIN .002.
 1. CRIMPING SURFACES TO BE $\sqrt{63}$.
- NOTES:

5	6-1011	1	Ø1/8 X 3/4 SPRING PIN
4	6-1010	1	Ø1/8 X 1/2 SPRING PIN
3	6-1036	1	Ø3/32 X 3/8 DOWEL PIN
2			
1	HX4-1064BK	1	PINNED DIE BLANK SET

RESTRICTED & CONFIDENTIAL		MATERIAL		ITEM		PART NO.		QTY.		DESCRIPTION/REMARKS			
CONFIDENTIAL PROPERTY OF DANIELS MANUFACTURING CORP. NOT TO BE DISCLOSED TO OTHERS, REPRODUCED OR USED FOR ANY OTHER PURPOSE, EXCEPT AS AUTHORIZED IN WRITING BY DANIELS MANUFACTURING. MUST BE RETURNED TO DANIELS MANUFACTURING CORP. ON COMPLETION OF ORDER OR OTHER PURPOSE FOR WHICH LENT.		(OHTS-06)		DRN. D.DEPAIVA DATE 6-16-94		CHK'D. DE DATE 6-94		APP'D. DATE		TITLE DIE SET			
		HEAT TREAT		HRC 52-55		APP'D. DATE		APP'D. DATE					
		DO NOT SCALE DRAWING		FINISH		TOLERANCE:		UNLESS OTHERWISE SPECIFIED		WHERE USED:		SHEET OF	
BLACK OXIDE PER MIL-C-13924		BLACK OXIDE PER MIL-C-13924		FRACTIONS±1/32 ANGLES±1/2°		SIZE B SCALE 2X		CAD P/N Y1660P		1 1			
				.X: ±.020 .XX: ±.010		.XXX: ±.005 .XXXX: ±.0005		POSTING		P/N Y1660P		REV. B	
				REMOVE BURRS & BREAK SHARP EDGES .005-.015									

