

GMT335 CRIMP TOOL

THIS TOOL MUST NOT BE USED IN ANY POWERED
“PRESS” AS DEFINED BY OSHA CFR 1910.211 (46)

SEE PAGE 4 FOR IMPORTANT INFORMATION CONCERNING
LIMITED WARRANTY AND LIMITATION OF LIABILITY

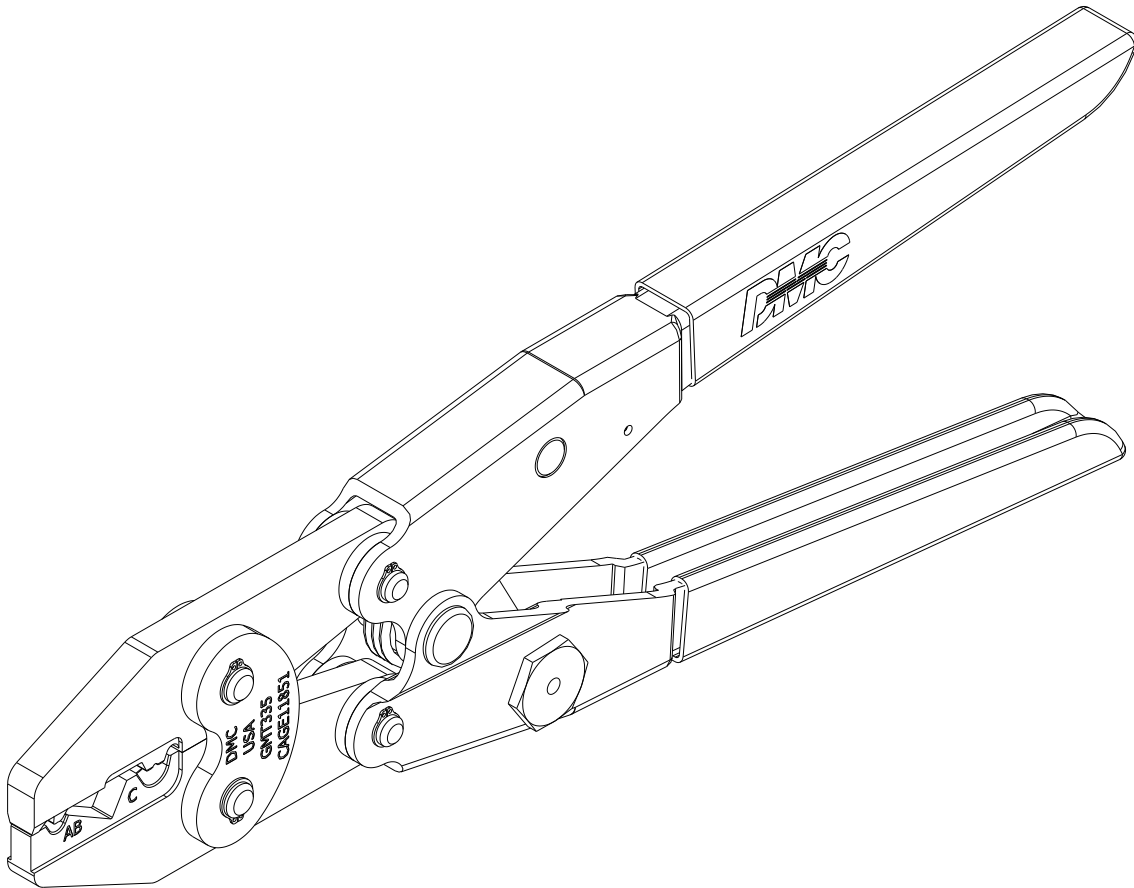

SPECIFICATIONS

1. The GMT335 crimp tool is designed to crimp the components listed in the table below:

TERMINAL PART NUMBER	CRIMP CAVITIES (SEE FIGURE 2) / WIRE SIZE	
	AB / 22-14	C / 10-12
M7928/15	-1, -2, -3	-4, -5, -6

- THESE CRIMP CAVITIES ARE FOR CRIMPING NON-INSULATED CONDUCTOR CRIMP BARRELS ONLY

GMT335 CRIMP TOOL

DATASHEET

2. A properly calibrated GMT335 crimp tool has the following characteristics:
 - a. Ratchet Adjustment (Set at factory):
A compression force of 30 - 50lb applied $1\frac{1}{8}" \pm \frac{1}{8}"$ from the end of the handles shall be required to completely close the jaws before the ratchet mechanism releases the handles
 - b. Crimp Cavity Gaging:
With the jaws fully closed, a "GO" gage shall fit in the space between the indenter and its corresponding cavity. A "NO-GO" gage shall not fit in this space.

Cavity gaging is listed in the table below:

TOOL CAVITY	"GO"	"NO-GO"
AB (22-18)	.0620	.0670
C (12-10)	.1120	.1170

3. Recommended Gage Configuration

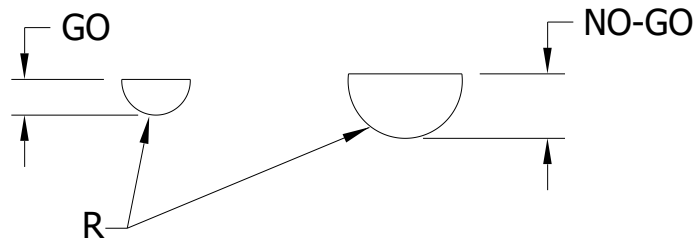

"GO" Gaging

Operate tool to fully closed position. Insert "GO" gage end as shown. The "GO" gage must pass freely between the opening of the crimp cavity.

"NO-GO" Gaging

Operate tool to fully closed position. Insert "NO-GO" gage end as shown. The "NO-GO" gage may partially enter the opening, but must not pass completely through the opening.

CAUTION!
DO NOT CRIMP GAGE!

4. Ratchet is secured to prevent unauthorized adjustment.
5. This tool is not equipped with an early release mechanism.

GMT335 CRIMP TOOL

DAILY MAINTENANCE

A properly crimp terminal is controlled by the following maintenance and inspection procedures.

- A. Clean all dust, dirt, moisture and other foreign matter from the crimp jaws that could damage the crimp area of the jaws.
- B. The pivot pin and ratchet pawl bearing surface should be lubricated to ensure smooth operation.
- C. When storing the tool, close the handles until the ratchet pawl is about to be released from the last tooth of the ratchet. This will help prevent the jaws from being damaged.

PERIODIC INSPECTION PROCEDURE

Visual inspections should be performed on the tool based on the amount of use, working conditions, operator skill and care.

- A. Clean tool crimp area with solvent, or brush.
- B. Check crimp area of jaws for damage.
- C. If tool jams or locks, check the ratchet for dirt and lubrication.

CARE OF TOOL

It is good practice to keep crimp jaw tips free of residual terminal material deposits and other debris. A small wire brush may be used for this purpose.

DMC strongly recommends that users:

1. DO NOT immerse tools in cleaning solution.
2. DO NOT spray oil into tool to lubricate except as noted in section B under DAILY MAINTENANCE.
3. DO NOT attempt to disassemble tool or make repairs.

This is a precision hand operated crimp tool and should be treated as such.

DMC offers complete refurbishing and recalibration services.

DMC engineers and manufactures complete tool kits to satisfy individual customer requirements, such as total aircraft support, general shop maintenance or production, on board ship and vehicle service etc...

Limitation of Liability

DANIELS MANUFACTURING CORPORATION IS NOT LIABLE FOR CONSEQUENTIAL OR SPECIAL DAMAGES OF ANY NATURE OR KIND RESULTING FROM THE USE, OR MISUSE, OF ANY OF ITS PRODUCTS. OWNERS AND USERS OF DMC PRODUCTS ASSUME FULL RESPONSIBILITY FOR INSTRUCTING THEIR EMPLOYEES IN THE PROPER AND SAFE USE OF SUCH PRODUCTS.

Limited Warranty

DMC (Daniels Manufacturing Corporation) warrants each new product sold by it to be free from defects in material and workmanship under normal use and service. DMC's obligation under this warranty is limited to the free correction or, at DMC's option, the refund of the purchase price of any such product which proves defective in normal service within ninety (90) days after delivery to the first user, provided that the product is returned to DMC with all transportation charges prepaid and which shall appear to DMC's satisfaction, after DMC's inspection, to have been defective in material and workmanship, it being understood that DMC products are not consumer products. This warranty shall not cover any damage to any product which, in the opinion of DMC, was caused by normal wear, misuse, improper operation, tampering, neglect or accident. This warranty is in lieu of all other warranties express or implied. No warranty, express or implied, is made or authorized to be made or assumed with respect to products of Daniels Manufacturing Corporation other than those herein set forth.