

REVISIONS

REV SYM	ECO NUMBER	DESCRIPTION	BY DATE	APP'D DATE
1	NA	ORIGINAL RELEASE	ENF 7-1-10	RRR 7-1-10

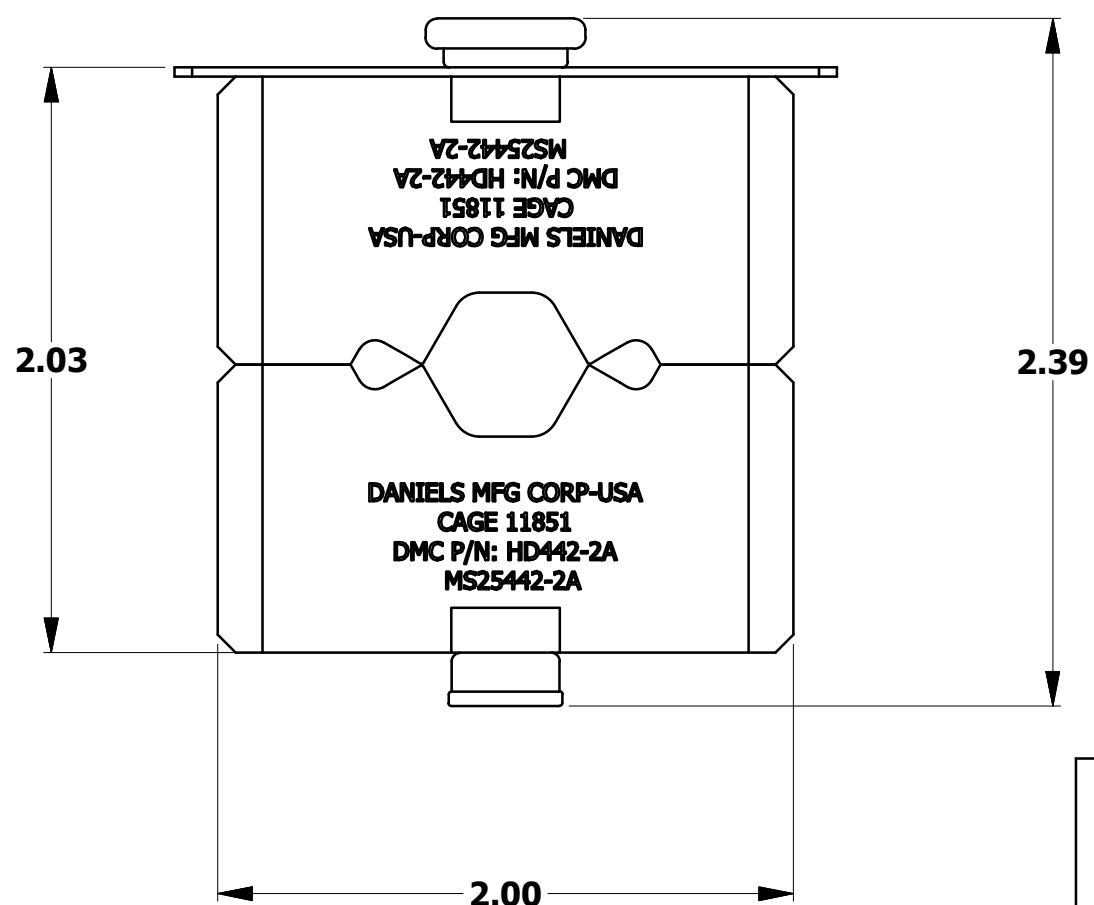
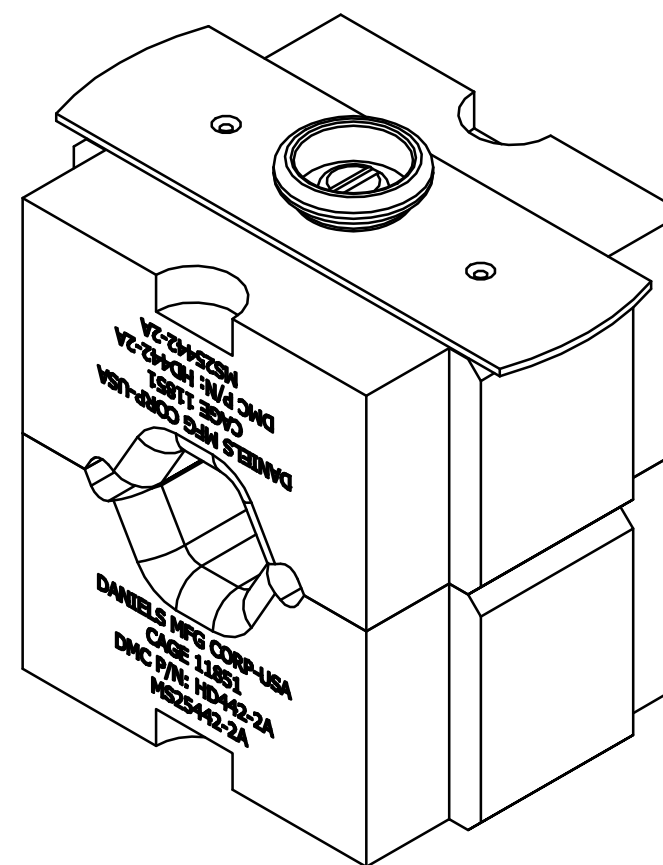
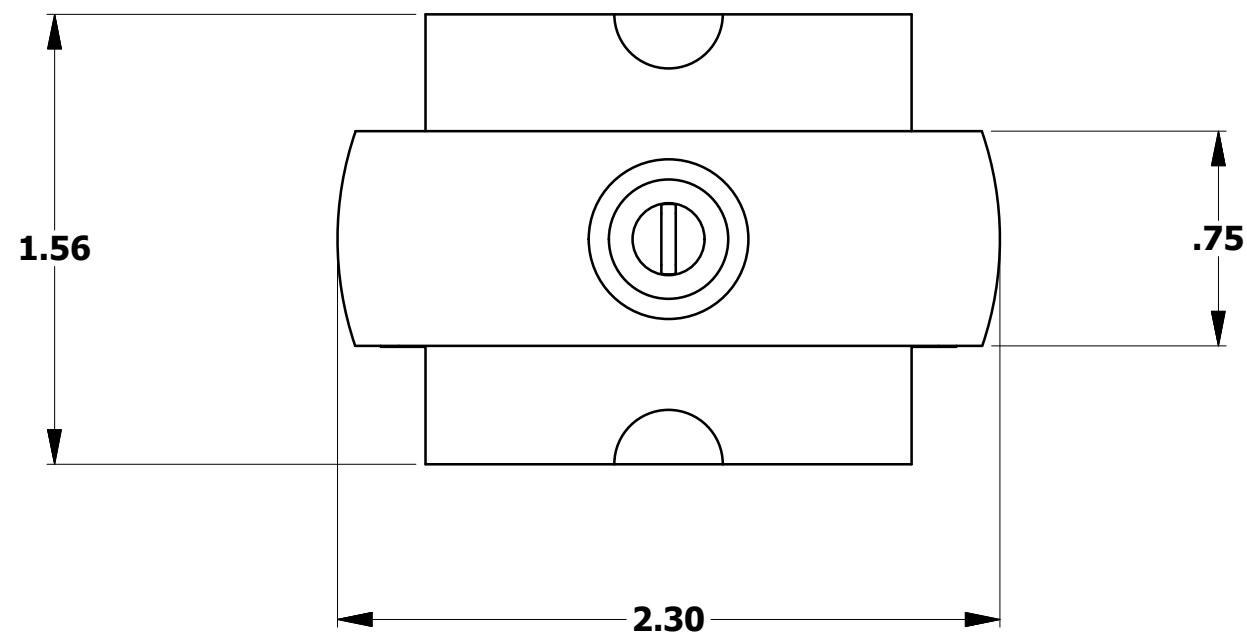

UNCONTROLLED DOCUMENT
WILL NOT BE UPDATED

NOTES:

1. DIE SET FOR USE WITH AS70991 ALUMINUM TERMINALS
2. GAGING DIMENSION .500 CHECK WITH GAGE G1132 (MS25472-4)

RESTRICTED & CONFIDENTIAL		MATERIAL	ITEM	PART NO.	QTY.	DESCRIPTION/REMARKS																
<p>CONFIDENTIAL PROPERTY OF DANIELS MANUFACTURING CORP. NOT TO BE DISCLOSED TO OTHERS, REPRODUCED OR USED FOR ANY OTHER PURPOSE EXCEPT AS AUTHORIZED IN WRITING BY DANIELS MANUFACTURING. MUST BE RETURNED TO DANIELS MANUFACTURING CORP. ON COMPLETION OF ORDER OR OTHER PURPOSE FOR WHICH LENT.</p> <p>CREATED FROM AN INVENTOR MODEL. CHANGES MUST BE REFLECTED IN THE 3D PART</p> <p>DO NOT SCALE DRAWING</p>		NA	DRN. Erik Francoforte CHK'D. RRR	DATE 7-1-10 DATE 7-1-10		<p>DMC DANIELS MANUFACTURING CORP. ORLANDO, FLORIDA CAGE 11851</p> <p>TITLE DIE SET ENVELOPE DRAWING (MS25442-2A)</p>																
		HEAT TREAT	APP'D.	DATE																		
		FINISH	APP'D.	DATE																		
			<p>TOLERANCE: UNLESS OTHERWISE SPECIFIED FRACTIONS ± 1/32 ANGLES ± 1/2 DECIMAL INCHES: .X ± .020 .XX ± .010 .XXX ± .005 .XXXX ± .0005 REMOVE BURRS AND BREAK SHARP EDGES .005-.015</p>			<p>WHERE USED:</p> <table border="1"> <tr> <td>SIZE</td> <td>SCALE</td> <td>CAD P/N</td> <td>SHEET OF</td> </tr> <tr> <td>B</td> <td>NTS</td> <td>HD442-2A-ENV</td> <td>1 1</td> </tr> <tr> <td>POSTING</td> <td></td> <td>P/N</td> <td>REV.</td> </tr> <tr> <td></td> <td></td> <td>HD442-2A-ENV</td> <td>1</td> </tr> </table>	SIZE	SCALE	CAD P/N	SHEET OF	B	NTS	HD442-2A-ENV	1 1	POSTING		P/N	REV.			HD442-2A-ENV	1
SIZE	SCALE	CAD P/N	SHEET OF																			
B	NTS	HD442-2A-ENV	1 1																			
POSTING		P/N	REV.																			
		HD442-2A-ENV	1																			