

REVISIONS				
REV SYM	ECO NUMBER	DESCRIPTION	BY DATE	APP'D DATE
1	NA	ORIGINAL RELEASE	ENF 7-1-10	RRR 7-1-10

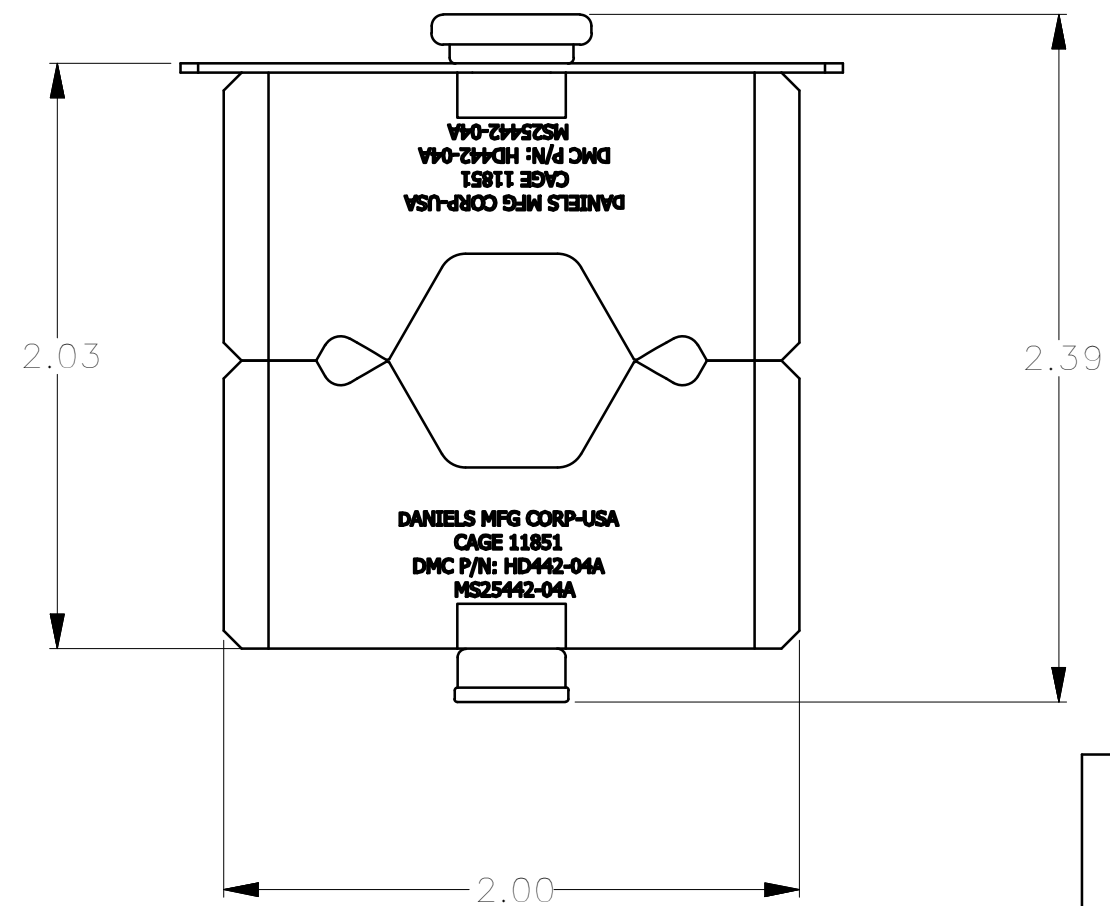
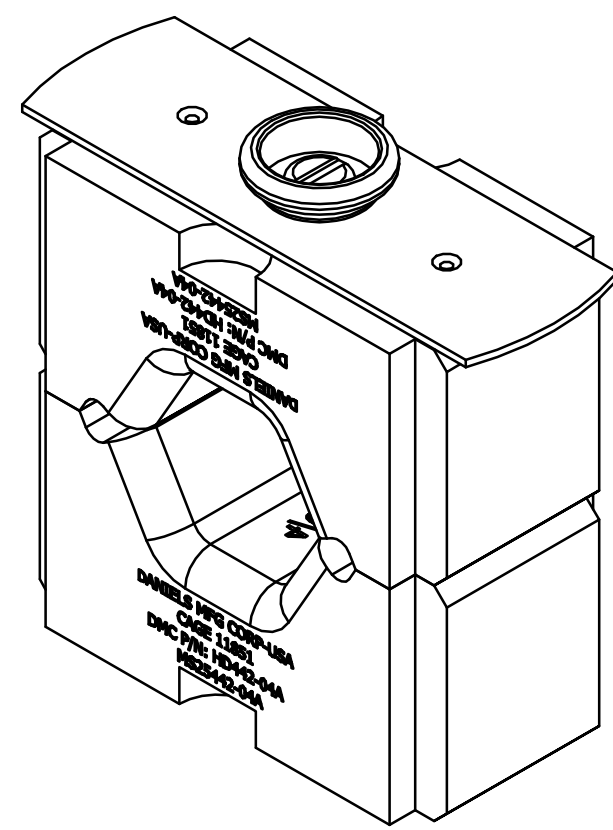
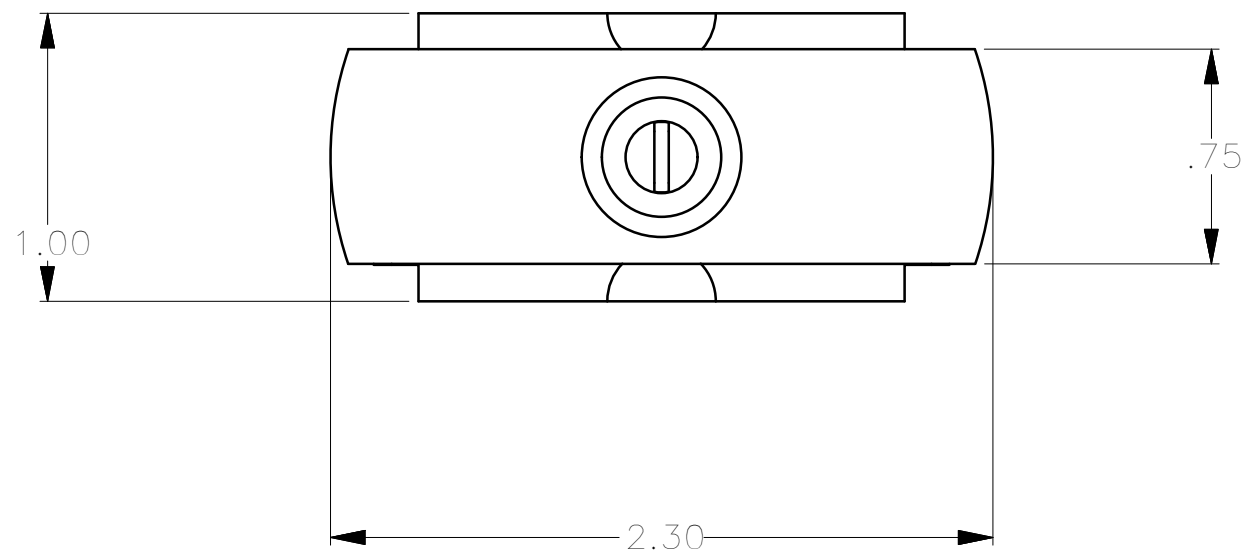

UNCONTROLLED DOCUMENT
WILL NOT BE UPDATED

NOTES:

1. DIE SET FOR USE WITH AS70991 ALUMINUM TERMINALS
2. GAGING DIMENSION .742 CHECK WITH GAGE G1137 (MS25472-9)

RESTRICTED & CONFIDENTIAL		MATERIAL	ITEM	PART NO.	QTY.	DESCRIPTION/REMARKS
CONFIDENTIAL PROPERTY OF DANIELS MANUFACTURING CORP. NOT TO BE DISCLOSED TO OTHERS, REPRODUCED OR USED FOR ANY OTHER PURPOSE EXCEPT AS AUTHORIZED IN WRITING BY DANIELS MANUFACTURING. MUST BE RETURNED TO DANIELS MANUFACTURING CORP. ON COMPLETION OF ORDER OR OTHER PURPOSE FOR WHICH LENT.		NA	DRN. Erik Francoforte	DATE 7-1-10	DANIELS MANUFACTURING CORP. ORLANDO, FLORIDA CAGE 11851	
		HEAT TREAT	CHK'D. RRR	DATE 7-1-10		
CREATED FROM AN INVENTOR MODEL. CHANGES MUST BE REFLECTED IN THE 3D PART MODEL.		NA	APP'D.	DATE	TITLE	
		FINISH	APP'D.	DATE	DIE SET ENVELOPE DRAWING (MS25442-04A)	
DO NOT SCALE DRAWING		NA	TOLERANCE: UNLESS OTHERWISE SPECIFIED FRACTIONS ± 1/32 ANGLE ± 1/2 DECIMAL INCHES: .X ± .020 .XX ± .010 .XXX ± .005 .XXX ± .0005 REMOVE BURRS AND BREAK SHARP EDGES .005-.015		WHERE USED: SIZE B SCALE NTS CAD P/N HD442-04A-ENV SHEET OF 1	
					POSTING P/N HD442-04A-ENV REV. 1	