

USERS MUST ASSURE THEY ARE USING THE CORRECT REVISION.

REVISIONS

REV	ECO NO.	DESCRIPTION	BY	DATE	APP'D BY	DATE
A	N/A	ORIGINAL RELEASE	CG	4/5/18		

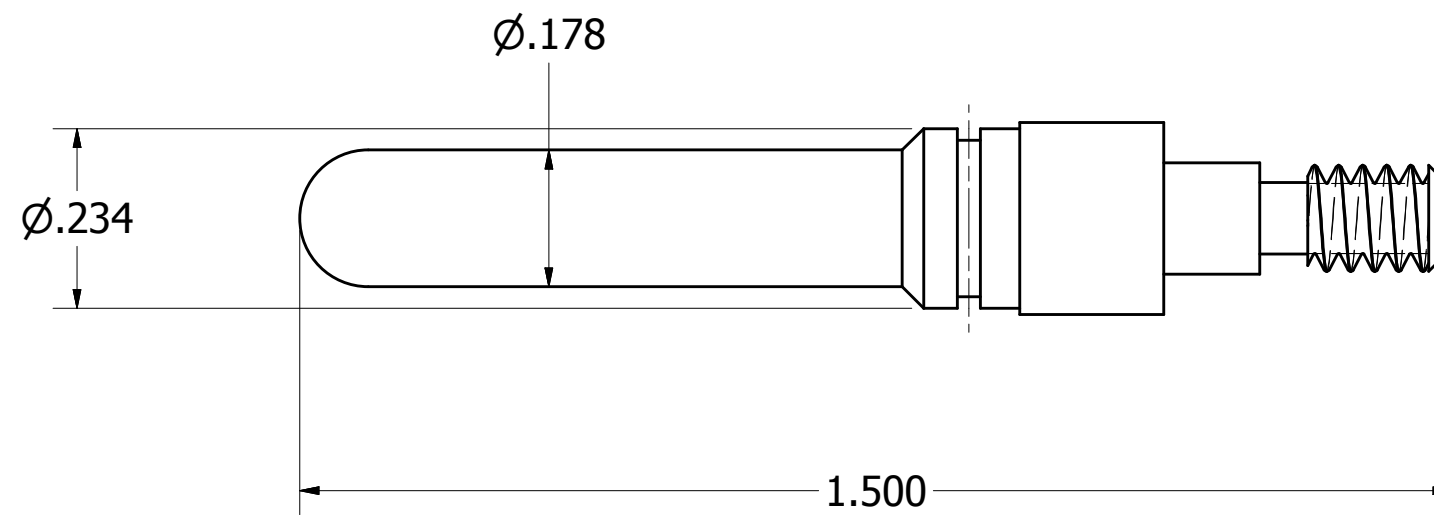

**UNCONTROLLED DOCUMENT
WILL NOT BE UPDATED**

DIMENSIONS IN INCHES - UNLESS OTHERWISE SPECIFIED

NOTES:

MATERIAL	ITEM	PART NO.	QTY.	DESCRIPTION / REMARKS
N/A	DRN. CG CHK'D.	DATE 11/21/2017 DATE		DMC DANIELS MANUFACTURING CORP. ORLANDO, FLORIDA CAGE 11851
RESTRICTED & CONFIDENTIAL CONFIDENTIAL PROPERTY OF DANIELS MANUFACTURING CORP. NOT TO BE DISCLOSED TO OTHERS. REPRODUCTION OR USED FOR ANY OTHER PURPOSE EXCEPT AS AUTHORIZED IN WRITING BY DANIELS MANUFACTURING. MUST BE RETURNED TO DANIELS MANUFACTURING CORP. ON COMPLETION OF ORDER OR PURPOSES FOR WHICH LENT.	HEAT TREAT	N/A		TOLERANCE: UNLESS OTHERWISE SPECIFIED FRACTIONS ± 1/32 ANGLE ± 1/2° DECIMAL INCHES: .X ± .020 .XX ± .010 .XXX ± .005 .XXXX ± .0005 REMOVE BURRS AND BREAK SHARP EDGES .005 - .015 SURFACE FINISH TO BE 63/ OR BETTER ALL OVER
CREATED FROM AN INVENTOR MODEL. CHANGES MUST BE REFLECTED IN THE 3D PART	FINISH	N/A		TITLE TIP, SOCKET, RETENTION TESTER #6 ENVELOPE DRAWING WHERE USED:
DO NOT SCALE DRAWING				SIZE B SCALE 4 : 1 CAD P/N 67-006-01-ENV SHEET 1 OF 1 DWG. NO. 67-006-01-ENV REV. A

