

REVISIONS				
REV. SYM.	E.C.O. NUMBER	DESCRIPTION	BY DATE	APP'D DATE
1		ORIGINAL RELEASE	TD 6-30-11	

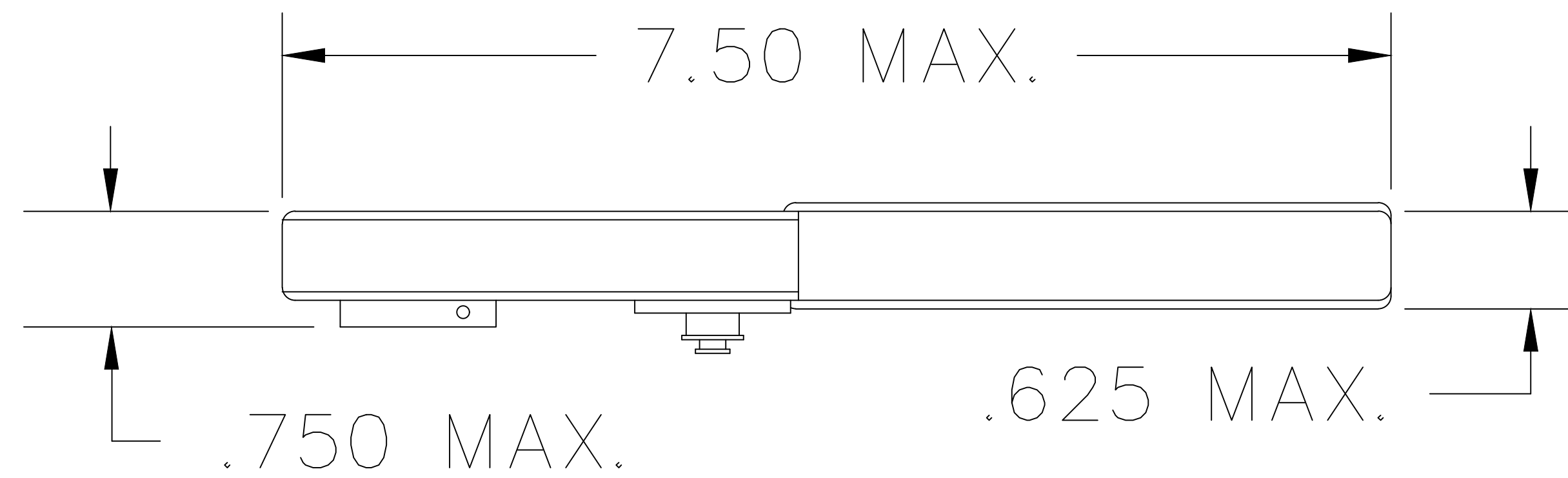

**UNCONTROLLED DOCUMENT
WILL NOT BE UPDATED**

DIMENSIONS IN INCHES - UNLESS OTHERWISE SPECIFIED

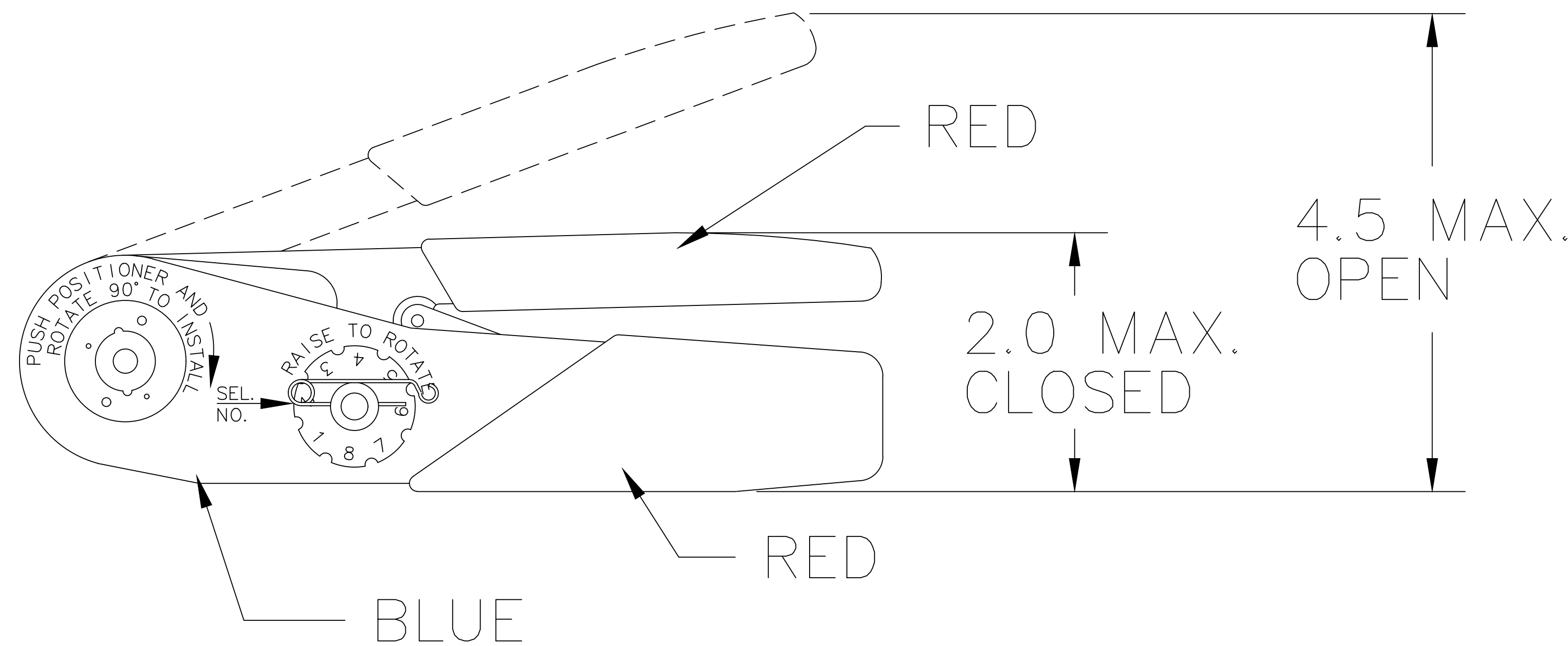

DIE CLOSURES		
SEL NO	Ø GO	Ø NO-GO
1	.0070	.0090
2	.0095	.0115
3	.0120	.0140
4	.0150	.0170
5	.0180	.0200
6	.0225	.0250
7	.0260	.0285
8	.0305	.0330

USE GAGE G822 AT SELECTOR SETTING 8

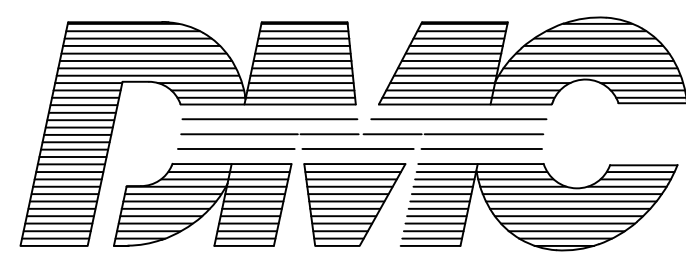
<p><u>RESTRICTED & CONFIDENTIAL</u></p> <p>CONFIDENTIAL PROPERTY OF DANIELS MANUFACTURING CORP. NOT TO BE DISCLOSED TO OTHERS, REPRODUCED OR USED FOR ANY OTHER PURPOSE, EXCEPT AS AUTHORIZED IN WRITING BY DANIELS MANUFACTURING. MUST BE RETURNED TO DANIELS MANUFACTURING CORP. ON COMPLETION OF ORDER OR OTHER PURPOSE FOR WHICH LENT.</p>	MATERIAL	ITEM	PART NO.	QTY.	DESCRIPTION/REMARKS		
	HEAT TREAT	DRN.	<i>Tony Dilworth</i>	DATE	6-30-11	 DANIELS MANUFACTURING CORP. ORLANDO, FLORIDA CAGE 11851	
		FINISH	CHK'D.		DATE		
	DO NOT SCALE DRAWING		APP'D.		DATE	TITLE ENVELOPE DRAWING CRIMPING TOOL	
APP'D.				DATE	WHERE USED:		
NOTE: THIS DRAWING IS AN OUTLINE DRAWING OF THE RESPECTIVE DMC PART NUMBER INDICATED. ACTUAL DMC PART NUMBER IS DRAWING NUMBER WITHOUT THE "-ENV" SUFFIX.			SIZE	SCALE	CAD P/N		SHEET
			POSTING		MH995-ENV	1	1
					DWG. NO.	REV.	
					MH995-ENV	1	