

**UNCONTROLLED DOCUMENT  
WILL NOT BE UPDATED**

DIMENSIONS IN INCHES - UNLESS OTHERWISE SPECIFIED

REVISIONS					
REV	ECO NO.	DESCRIPTION	BY	DATE	APP'D BY
1		ORIGINAL RELEASE	K. KOONS	4/6/2023	

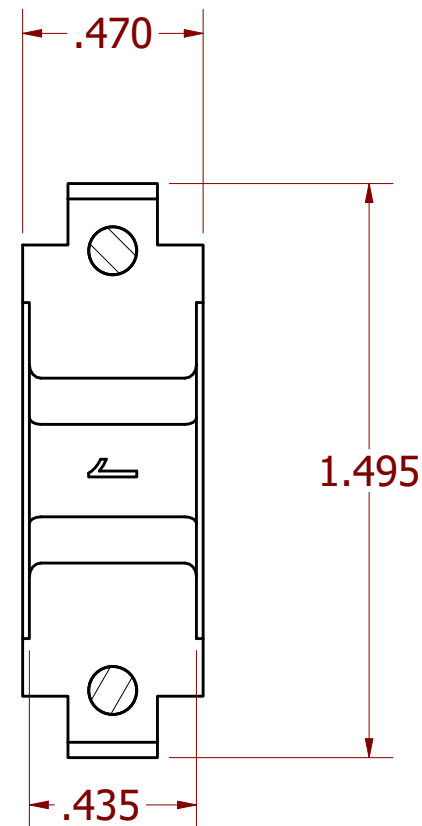
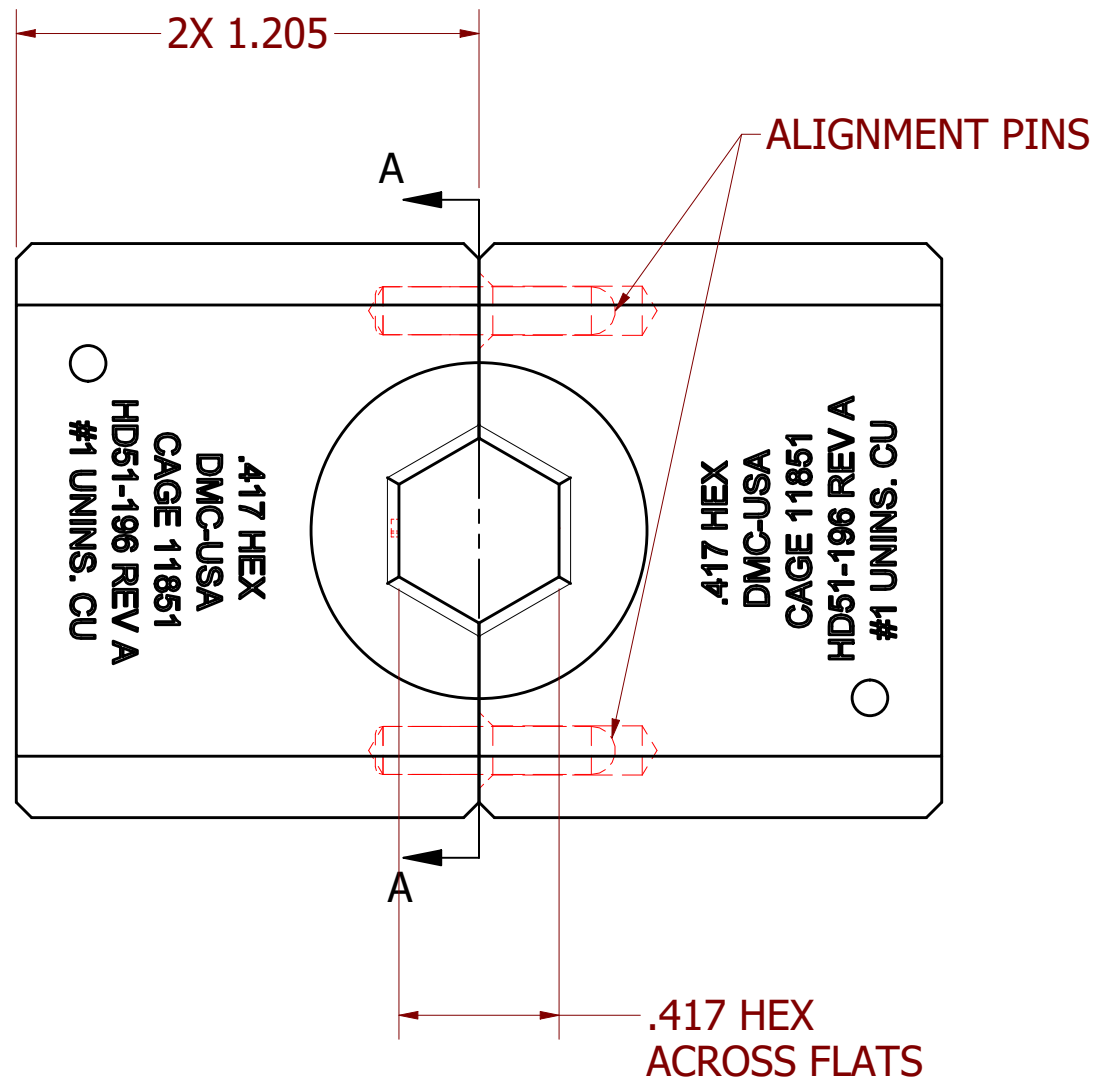

SECTION A-A  
SCALE 2 : 1

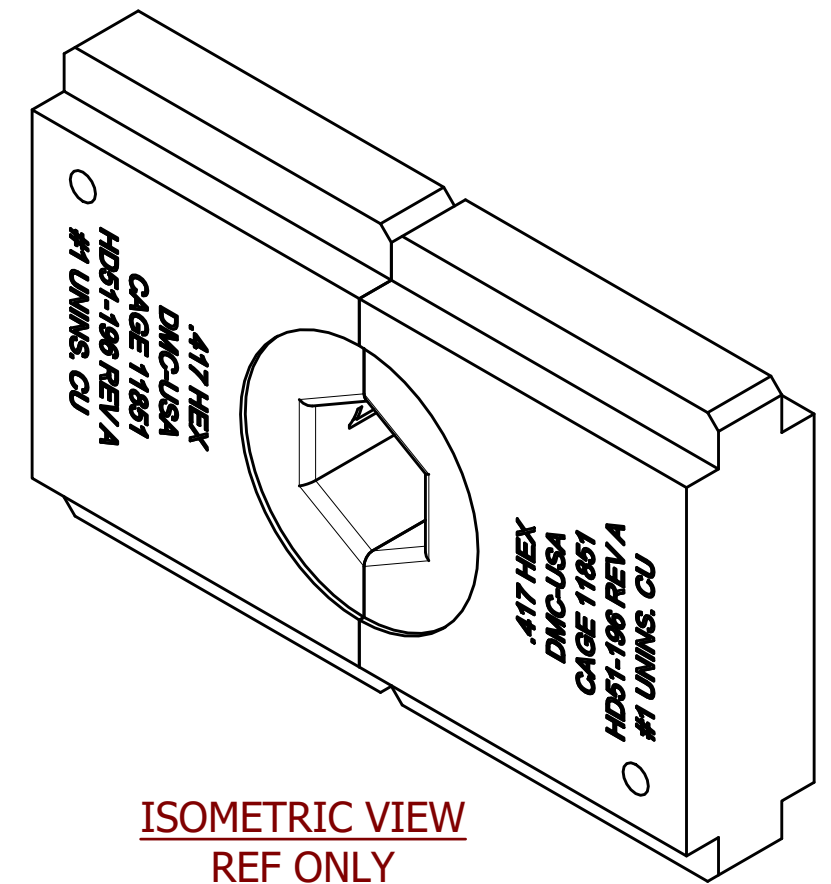

ISOMETRIC VIEW  
REF ONLY

1. TO CRIMP 1AWG UN-INSUALTED COPPER LUGS AND SPLICES

NOTES:

RESTRICTED & CONFIDENTIAL  
CONFIDENTIAL PROPERTY OF DANIELS MANUFACTURING CORP. NOT TO BE DISCLOSED TO OTHERS. REPRODUCTION OR USED FOR ANY OTHER PURPOSE EXCEPT AS AUTHORIZED IN WRITING BY DANIELS MANUFACTURING. MUST BE RETURNED TO DANIELS MANUFACTURING CORP. ON COMPLETION OF ORDER OR PURPOSES FOR WHICH LENT.

DRN. KIRK C KOONS	DATE 1/11/2023	INTERPRET PER ASME Y14.5M-2018	
CHK'D JC	DATE 1/11/2023	DANIELS MANUFACTURING CORP. ORLANDO, FLORIDA CAGE 11851	
APP'D JC	DATE 1/11/2023		
NOTE: THIS DRAWING IS AN OUTLINE DRAWING OF THE RESPECTIVE DMC PART NUMBER INDICATED.		TITLE DIE SET #1 AWG UNINS. Cu ENVELOPE DRAWING	
WHERE USED:		SIZE B	SCALE N.T.S.
		CAD NO. HD51-196-ENV	SHEET 1 OF 1
		PART NO. HD51-196	REV. 1