

DANIELS XHD51 HYDRAULIC CRIMP HEAD

DMC DANIELS
MANUFACTURING
CORPORATION
DATASHEET

SEE PAGE 2 FOR IMPORTANT INFORMATION CONCERNING
LIMITED WARRANTY, AND LIMITATION OF LIABILITY.

INTRODUCTION

This datasheet covers the proper use of the XHD51 hydraulic crimp head. Read the information contained herein carefully before using the tool.

DESCRIPTION

The crimp head is operated by using one of the Daniels HPU1*M hydraulic power units. See the separate datasheet provided with the power unit for more specific operating instructions. The XHD51 has a force output of 5.5 tons and weighs 3.8lb.

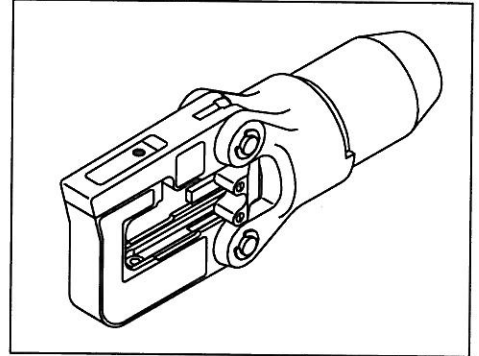

SELECTION OF CRIMPING DIE

Determine proper crimping die set to be used for the crimp. Consult the factory for standard die sets. Custom die sets can be designed by DMC for almost any application.

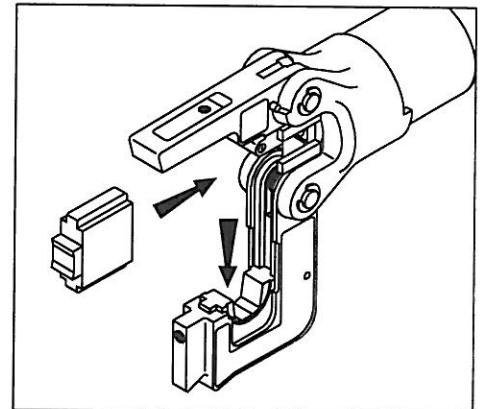

OPERATING PROCEDURES

1. Open the head and insert the crimping dies. The head assembly has two slots to slide the dies in and out safely.

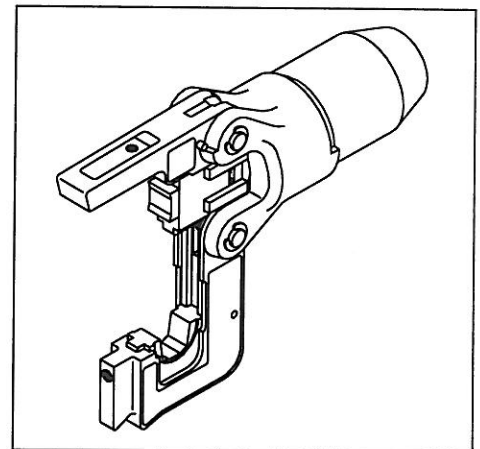

2. Lock the head over the connector and operate the HPU1*M power unit to start the flow of hydraulic fluid into the system.

Continue operating the power unit until the gage on the power unit reads 10,000 psi. DO NOT release the pressure in the system until 10,000 psi is reached, EXCEPT in cases of emergency. Crimping with less than 10,000 psi will result in insufficient compression, and produce bad crimps.

The manual and air driven power units will hold pressure until they are released.

Operate the power unit to release pressure and retract the cylinder.

The battery and electric driven power units automatically retract when 10,000psi is achieved.

3. To remove the dies, open the head and remove dies by sliding along the slot.

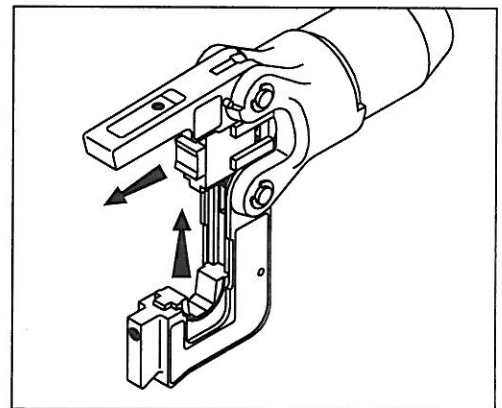
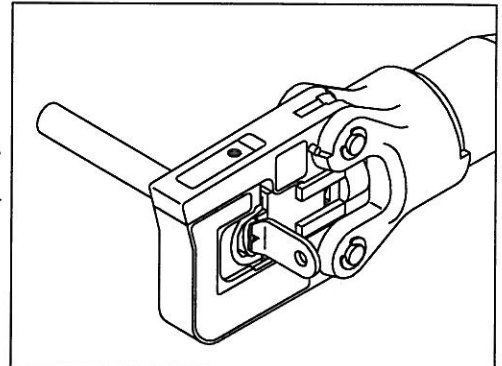

LIMITATION OF LIABILITY

DANIELS MANUFACTURING CORPORATION IS NOT LIABLE FOR CONSEQUENTIAL OR SPECIAL DAMAGES OF ANY NATURE OR KIND RESULTING FROM THE USE, OR MISUSE, OF ANY OF ITS PRODUCTS. OWNERS AND USERS OF DMC PRODUCTS ASSUME FULL RESPONSIBILITY FOR INSTRUCTING THEIR EMPLOYEES IN THE PROPER AND SAFE USE OF SUCH PRODUCTS.

LIMITED WARRANTY

DMC (Daniels Manufacturing Corporation) warrants each new product sold by it to be free from defects in material and workmanship under normal use and service. DMC's obligation under this warranty is limited to the free correction or, at DMC's option, the refund of the purchase price of any such product which proves defective in normal service within ninety (90) days after delivery to the first user, provided that the product is returned to DMC with all transportation charges prepaid and which shall appear to DMC's satisfaction, after DMC's inspection, to have been defective in material or workmanship, it being understood that DMC products are not consumer products. This warranty shall not cover any damage to any product which, in the opinion of DMC, was caused by normal wear, misuse, improper operation, tampering, neglect or accident. This warranty is in lieu of all other warranties express or implied. No warranty, express or implied, is made or authorized to be made or assumed with respect to products of Daniels Manufacturing Corporation other than those herein set forth.